

Installation instructions for **THERMO-X-AIR**

Please read instructions carefully before installation.

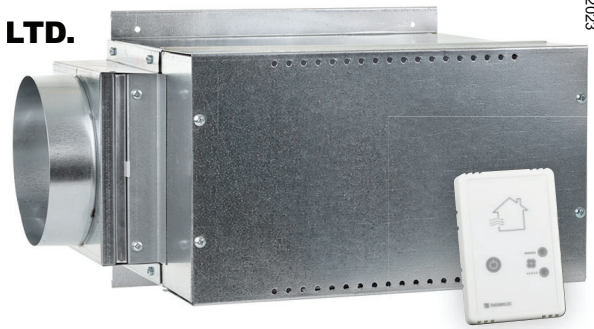

Mechanical Installation.

1 - The direction of airflow is reversible by simply rotating the unit 180° in the **horizontal** position only. This is possible due to the automatic cutouts on the top *and* bottom of the unit.

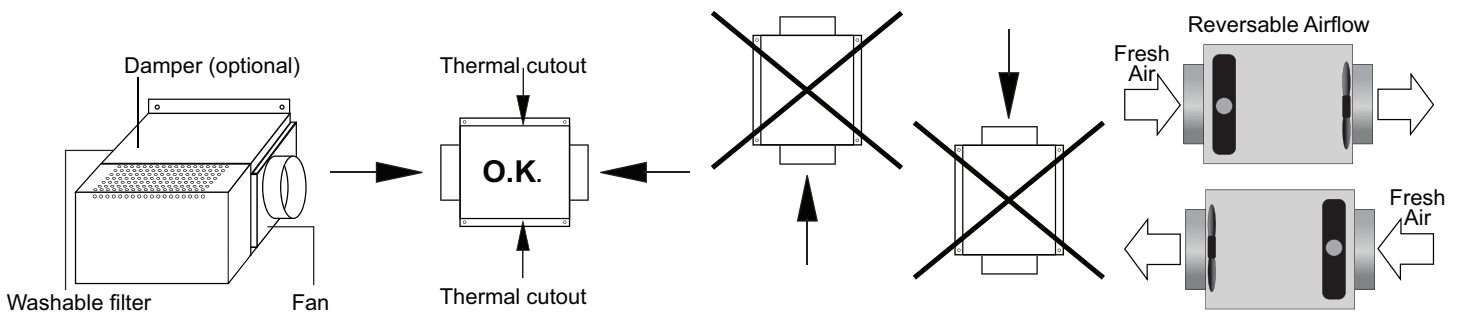

2 - Do not install elbows closer than 8 inches to the inlet or the outlet of the unit.

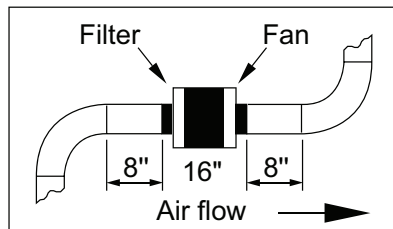

3 - Use 6" round insulated duct for the inlet connection and uninsulated for the outlet. Minimize the use of elbows.

4 - The electronic controller adjust the heating capacity to the volume of air and shuts down the heater when there is no air flow. The minimum amount of air required (in cubic feet per minute) to operate the unit is given in the last column of the table on side 2 (CFM).

5 - Attach the unit to a suitable support. This model is small enough to be located between standard 16" spaced floor joists. Always allow a minimum 1/2" clearance above the heater. To simplify installation, attach the mounting bracket and then hook the top of the unit on the bracket and only screw in the bottom flange.

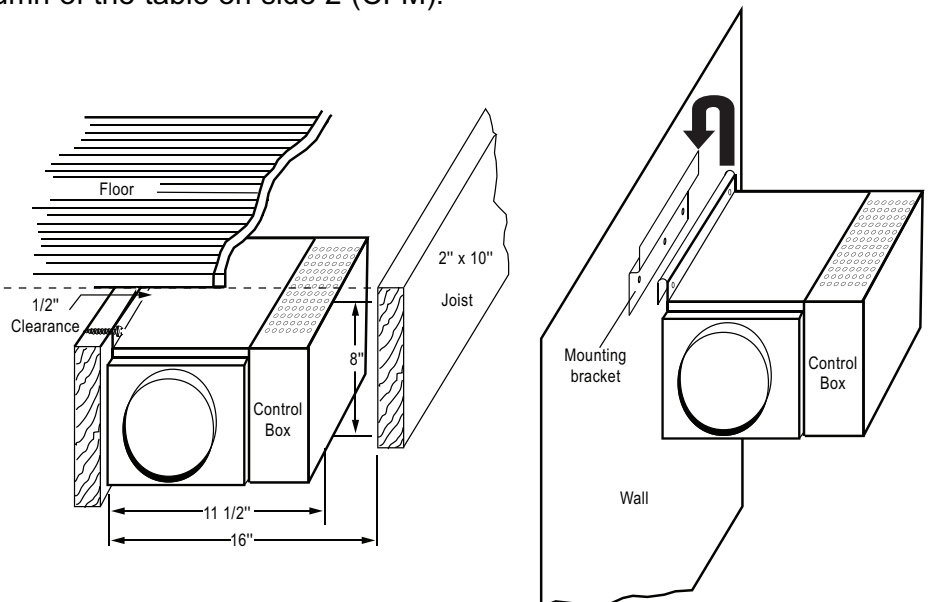

Electrical Installation

NOTE: When the Room Control AND a current sensor is connected to the D22-TFS the current sensor will take priority in switching on the unit.

- 1 - Please conform to all local and national electrical codes for wiring. The system should be supplied by a separate cable, of appropriate gauge, and with appropriate protection. Please refer to the following table.

Models THERMO-X-AIR	Recommended wire gauge and protection							Air Flow CFM
	Collar Dia.	KW	Volts	Amps.	Wire Gauge	Fuses		
FER-6-1.5-120	6	1.5	120/1	12.5	12	15	45	
FER-6-1.5-240	6	1.5	120/240/1	6.25	12	15	45	
FER-6-2.0-240	6	2.0	120/240/1	8.3	12	15	60	
FER-6-3.0-240	6	3.0	120/240/1	12.5	12	15	90	

To convert the air flow to liters/sec., multiply the value in CFM by 0.47.

- 2 - Install the one touch room control in an appropriate location on the wall according to the user's choice.
- 3 - After installing and wiring the system, use the potentiometer to adjust the desired temperature and the fan speed control to adjust the air volume.
- 4 - A connection to drive simultaneously a 120VAC max. 3 amps. exhaust fan is supplied to be used if required.

Remember: For technical assistance, please use our free help line: **1-800-336-9130**

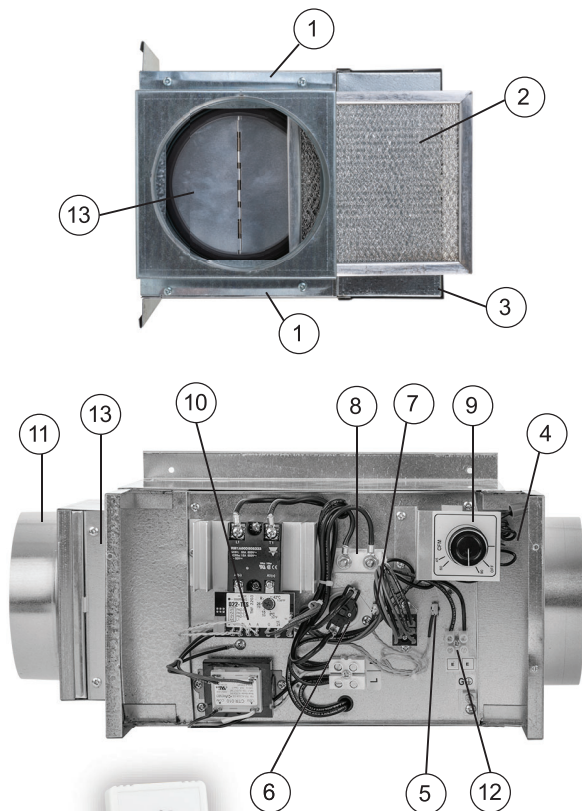

- 1-Automatic Reset Thermal Cut-outs (on top and bottom)
Safety feature preventing overheating; will reset automatically after cool-off.
- 2-Washable Filter
Easy access filter.
- 3-Enclosure
Corrosion resistant galvanized steel.
- 4-Fan
High quality tube axial fan with ball bearings for lowest noise and longest life.
- 5-Air Flow Sensor
Modulates the heating capacity according to the quantity of air flowing through the heater.
- 6-Manual Reset Thermal Cut-out
Additional safety feature which prevents the frame from overheating.
- 7-Temperature Sensor
Controls the heater proportionally to maintain the pre-set air temperature in the duct.
- 8-Open Coil Elements
Made of the highest grade nickel-chrome resistance wire, they will not age or oxidize, thus assuring longer heater life.
- 9-Fan Speed Control
To adjust the air volume.
- 10-Built-in Electronic Temperature Controller and Sensor
Proportionally modulates the heating load to match the exact capacity required, thus minimizing operating cost.
- 11-Round Collars
Simplifies the installation and considerably reduces field labor.
- 12-Connection for Exhaust Fan Supplied
120VAC up to 3 amps. max. output to drive simultaneously an exhaust fan when required.
- 13-Damper
Automatically opens when the heater is in operation.

One Touch Room Control
Allows full or intermittent ventilation.
Pilot lights indicate the selected mode.

120V

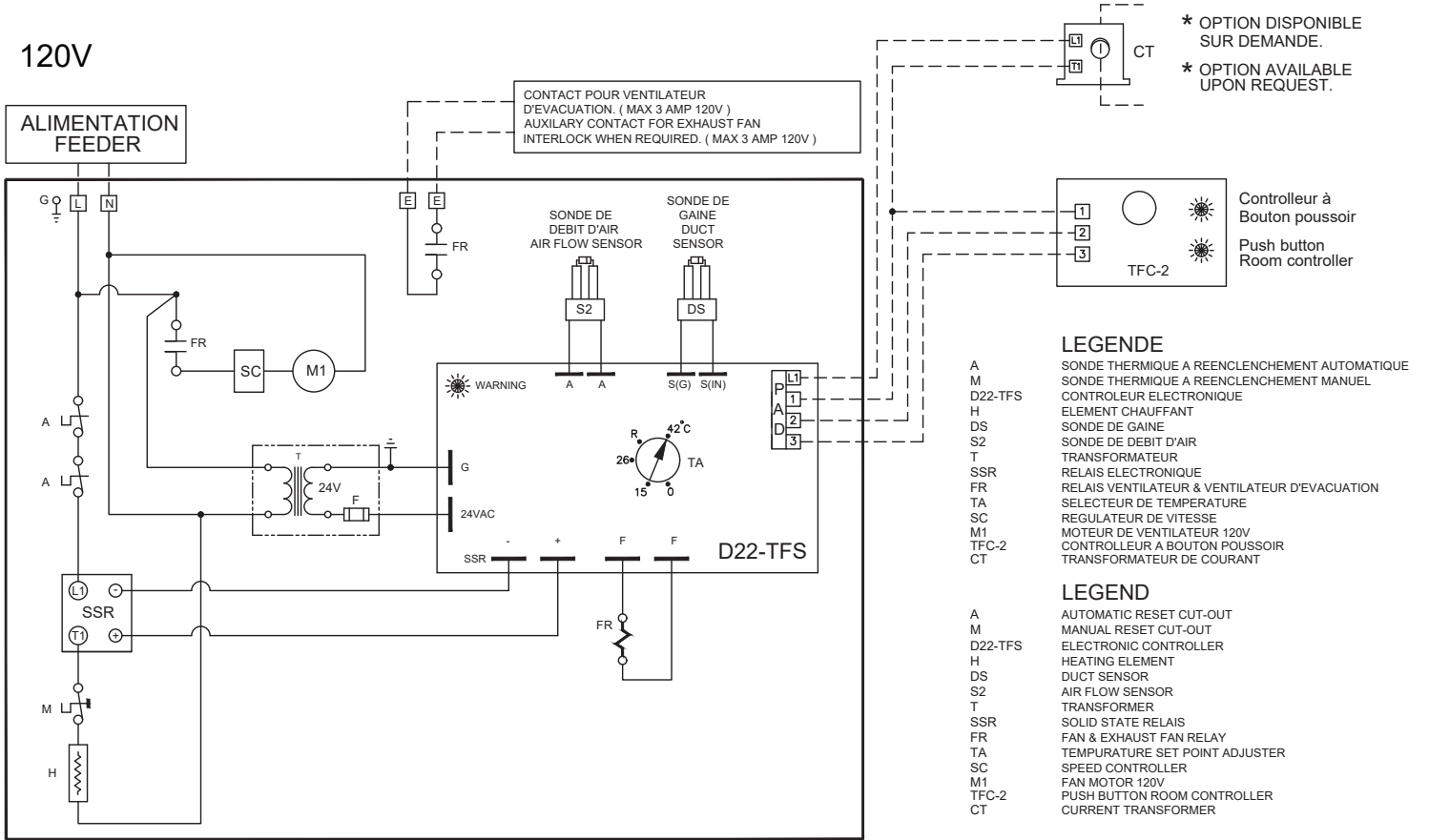

240V

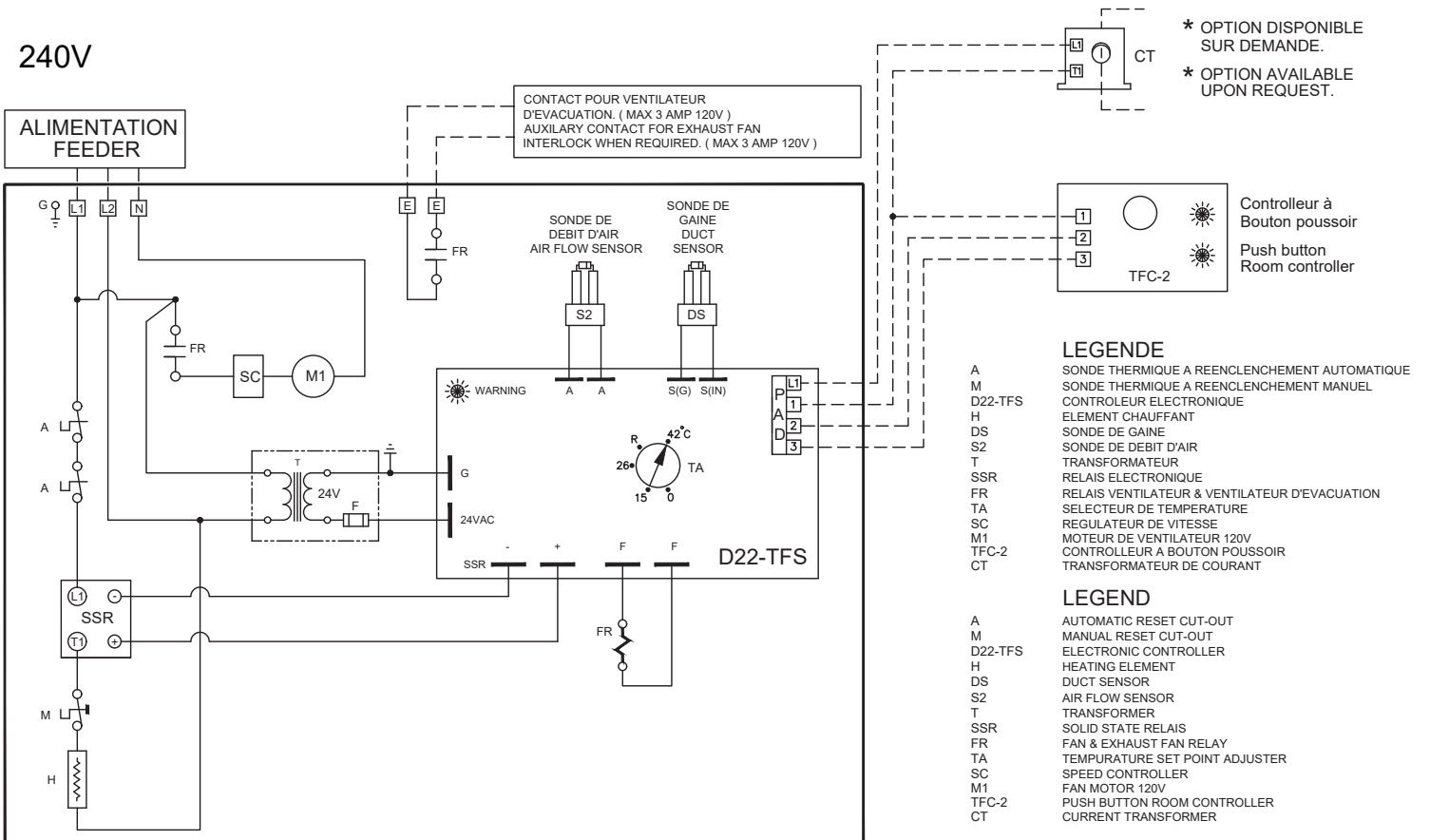

Room Controller Instructions

MINI FRESH AIR MAKE-UP – **THERMO-X-AIR**

Field of Application:

- Fresh Air Make-up for residential houses, condos or apartments.

Scope:

- Standard house from 1800 to 2000 square feet.
- An airflow of 60 cubic feet per minute (CFM) is required for a minimum of 2.0 KW.

Operating Procedure:

- 1 – Make sure the fan is adjusted at 60 CFM.
- 2 – Adjust the output temperature of the **THERMO-X-AIR** on the D22-TFS module.
- 3 – Use the push button Room Controller (installed near the entrance door) for either a continuous or intermittent operation, depending upon how many air changes you require.
- 4 – For a dry contact operation (on-off) please contact Thermolec.

N.B.

For homes with a surface area of more than 2000 square feet, the required airflow is 90 CFM for a minimum of 3.0 KW.

Connect the bathroom fan to the **F F** terminals in the **THERMO-X-AIR**.

The operation is exactly the same as the 60 CFM unit.



Push Button Room Controller

The buttons control three functions: Stop, Continuous Ventilation and Intermittent Ventilation. A pilot light confirms the chosen mode.

- | | | | |
|------------|-------|---|--------------------------|
| Function 1 | — | ○ | Stop |
| Function 2 | — | ● | Continuous Ventilation |
| Function 3 | | ● | Intermittent Ventilation |