

User and Maintenance Manual
for the Homeowner
and
Installation Instructions
for the Contractor

Steam Humidifier
by Thermolec

ACU≈STEAM

Split | 
Steam

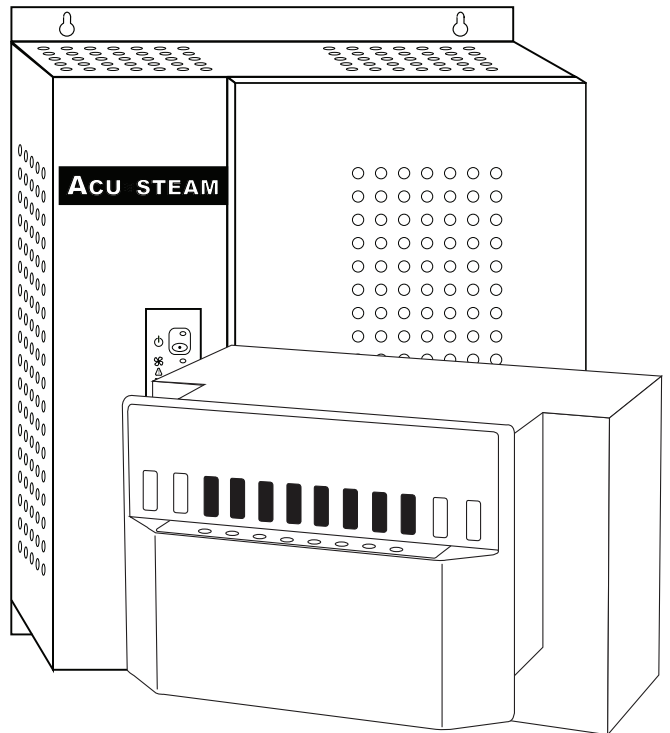
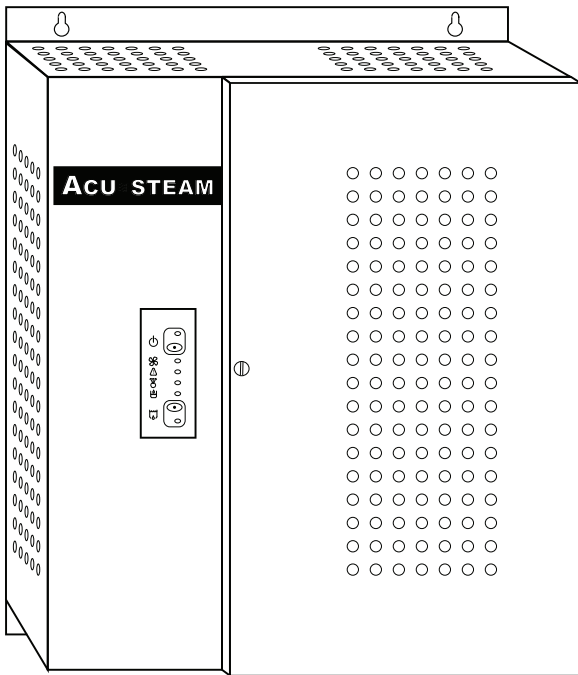

Please read this manual carefully before beginning installation.

Important Notice to the Contractor :

Once the installation is complete, please leave this manual with the customer for future reference.

1. Warnings and Disclaimer – Installation Precautions and Recommendations

Please read and understand the warnings and provided instructions fully before you begin this installation and keep them handy for future reference.

Sections specifically for Split Steam units are labeled  and **ACU≈STEAM** for the standard unit. All other sections are common to both models.

The manufacturer will assume no responsibility and the warranty will be void if the installer or the user does not adhere to the following precautions/recommendations :

IMPORTANT: This unit can not be installed in an attic space

1.1 **Water quality and hardness can significantly affect the maintenance frequency of your Acu- Steam humidifier. If the cold water supply as measured by grains per gallon (gpg) exceeds 7.0 gpg, the water is classified as hard and excessive scaling inside the tank reservoir is possible. If the water supply exceeds 180 mg/L, a water conditioner/softner is recommended to minimize the maintenance frequency (see section 8.).**

1.2 This humidifier will be connected to and used under water pressure and it must be installed in such a way that if a leak occurs, the water will not cause any damage to the property. Make sure all water connections are properly installed or a water leak could occur.

1.3 This humidifier is intended for use on ducted forced air furnaces and heat pumps as well as multi-fuel furnaces, which have at least one supply duct connected to the furnace and where a positive air pressure can be measured. **ACU≈STEAM**

1.4 Do not install a humidifier where the surrounding temperature may be 32°F (0°C) or colder. Freezing water will damage the humidifier.

1.5 Do not install the humidifier directly on the furnace housing. **ACU≈STEAM**

1.6 Always check that you are not about to cut or drill into an electrical accessory during installation.

1.7 Do not install a humidifier if the city water pressure exceeds 90 psi. Check the local codes related to pressure reduction.

1.8 Do not install the diffuser in the **supply duct if the pressure exceeds 0.5” Water Column (0.125 kPa).** **ACU≈STEAM**

1.9 The installation, wiring and plumbing of the humidifier must comply with national and local electrical, plumbing and building codes.

1.10 Electrical wiring and water tubes must not come in contact with sharp edges or hot surfaces.

1.11 Make certain an appropriate drain system is installed and there is no resistance to the flow of the discharged water.

1.12 Do not set the humidity level higher than that recommended or condensation damage could occur.

1.13 Please beware of sharp metal edges.

1.14 Always shut the power off before you start the installation or when doing maintenance. An electric shock from 120 or 240 volts could cause serious injury or death.

1.15 **Caution:** when you perform maintenance, please be careful because the unit can be **extremely hot**. Always allow enough time for the unit to cool down.

1.16 To prevent electric shock or injuries, never operate the humidifier without the covers as there are high voltage and hot components inside.

1.17 **This humidifier will only work with non demineralized water. The maximum water supply temperature is 86 °F (30 °C)**

HOME OWNER

CONTRACTOR

Instructions and User Manual for the Homeowner

2. View of the unit

2.1 External view of the humidifier. **Fig. 2a**

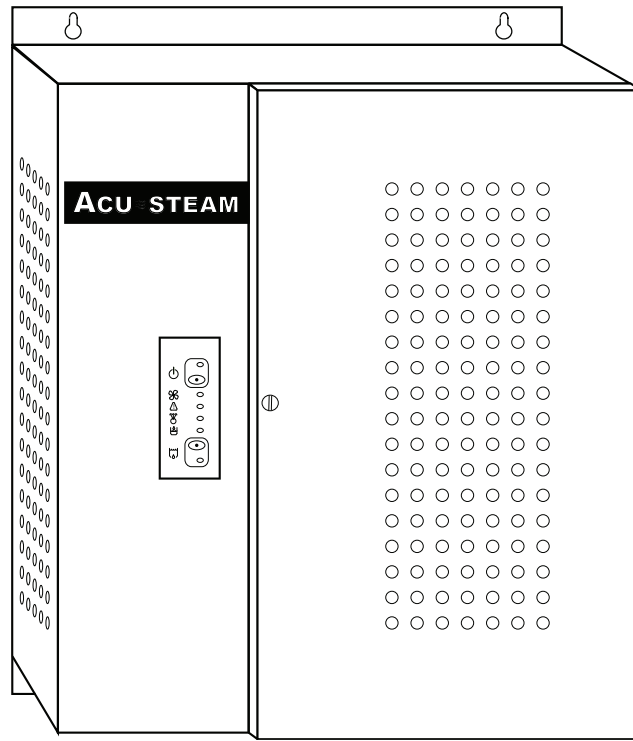

2.2 Water Tank Top View. Please see Fig. 2b.

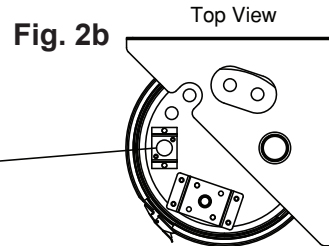

2.3 Water tank Side View. Please see Fig. 2c.

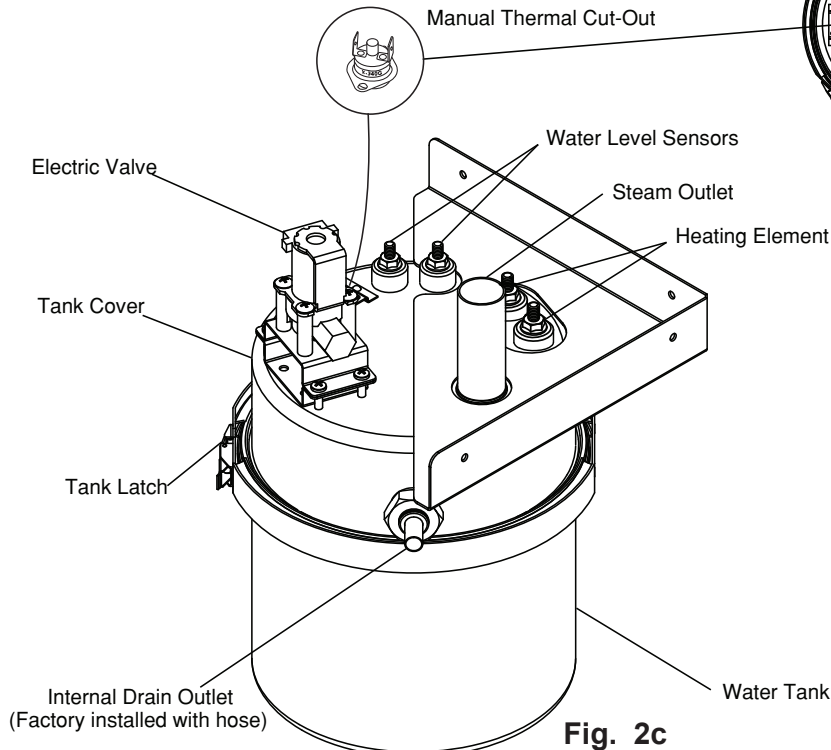

Fig. 2c

3. Startup

3.1 The startup of the humidifier is done as follows :

- Adjust the knob on the humidistat to the humidity level (percentage) desired.
- Confirm that the water supply valve is open.
- Put the main power ON at the electrical panel. The green pilot light comes ON on the LED panel. The humidifier is ready to work.

Working Principle :

3.2 Unlike other types of humidifiers which produce humidity by passing warm air through a moist pad, Acu- Steam produces humidity from **steam** dispersed directly into the air.

3.3 A humidistat installed on the wall controls the unit. You set the knob of the humidistat according to your desired level of humidity (35-45% recommended). Please read the next section about the Acu- Steam humidity control.

3.4 When the humidistat senses a need for humidity, it starts the humidification process.

3.5 The tank fills with water.

3.6 The electronic control starts the blower fan to move the air as the humidifier starts boiling water and producing steam. If the fan cannot start, the humidifier stops itself. Please note that it may take a few minutes to bring the water to a boil. The steam exits the water tank through the steam hose, moves through the steam diffuser installed in fan module and is released into the air.



3.6 The electronic control starts the blower fan in the furnace to move the air as the humidifier starts boiling water and producing steam. If the fan cannot start (i.e. there is no air movement to transport the steam or insufficient air pressure), the humidifier stops itself. Please note that it may take a few minutes to bring the water to a boil. The steam exits the water tank through the steam hose, moves through the steam diffuser installed in the warm air duct and is released into the duct where it mixes with the moving air.

ACU=STEAM

3.7 As water evaporates, the electric valve opens as needed to replenish the water in the tank.

3.8 When the humidity reaches the desired level, the humidifier stops producing steam. In order to remove scale and keep the tank as clean as possible, the humidifier drains after a certain number of steam producing cycles (see section 18.5 on page 26 of install manual for more details). If there is still a demand from the humidistat after draining, the tank refills and starts to produce steam again. This process is part of the self-cleaning feature.

3.9 When the humidistat is satisfied, the fan continues to run for a short period of time in order to eliminate the steam from the ducts and the unit goes to ready mode, waiting for the next call from the humidistat.

4. How to Control the Humidity

4.1 Humidity level and comfort are personal matters but it is generally acknowledged that a Relative Humidity of 35-45% is desirable. However, you should take the outside temperature into consideration before setting the humidity level in order to avoid condensation on the windows. Usually, a narrow strip of condensation around or at the bottom of the window is considered as normal.

4.2 If you installed an ACU-STEAM humidistat and an outdoor sensor, this adjustment will be done automatically through a function called outdoor reset. The outdoor sensor automatically reduces the humidistat setting according to the outdoor temperature during cold days; it does the opposite during mild days. Please see Fig. 4b for the percentage of relative humidity on the electronic humidistat label. The middle of the scale corresponds to the middle of the comfort zone, approximately 35% RH (Relative Humidity).

Note: There are no numbers printed on the Humidistat itself.

4.3 If you are using a humidistat by others, the humidity adjustment according to the outside temperature might have to be done manually. For your information, the following table shows the recommended setting of the humidistat according to the outside temperature. Please see Fig. 4a.

Outside Temperature	Recommended Setting
-22°F (-30°C)	15%
-13°F (-25°C)	20%
-4°F (-20°C)	25%
+5°F (-15°C)	30%
+14°F (-10°C)	35%
above 23°F (-5°C)	40%

Fig. 4a

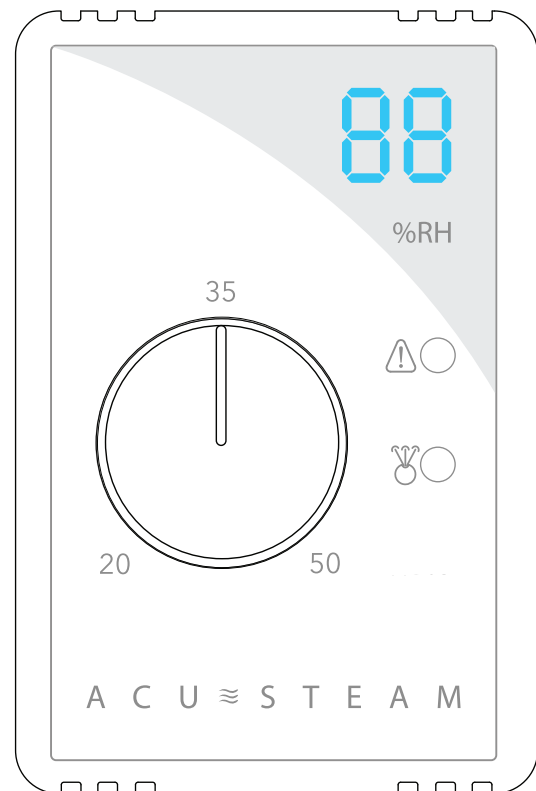

Fig. 4b

4.4 No matter which humidification system you are using, please do not forget that the humidity level cannot adjust quickly. It may take some time to build up the humidity to your comfort level. Depending on the dryness of the house, carpets, furniture, drapes and wood will absorb moisture before you can feel the change.

4.5 If the house remains unoccupied during the winter season, set the humidistat to the minimum set point in order to prevent condensation.

5. Functions of the Electronic Circuit

5.1 The electronic board located inside the unit controls all the humidifier functions. The front LED panel is equipped with pilot lights indicating the status of the humidifier. Please see [Fig.5a](#). Please refer to Article 5.2 for the description of the functions.

The red pilot light, which is a warning light, can either glow all the time or flash when activated. In case of error, the humidifier enters standby mode. The flashing of the pilot lights indicates which error happened. The error recognition sequence is as follows :

- The green pilot light near the power button blinks once;
- The red light flashes a certain number of times, this is the error code;
- A pause with no light at all;
- Another blink of the green light, once;
- Another series of flashing of the red light;
- And so on until the condition is reset or service is performed.
- Shutting the power OFF at the breaker in the main panel or depressing the power button until the green light is fully on will reset the error code.

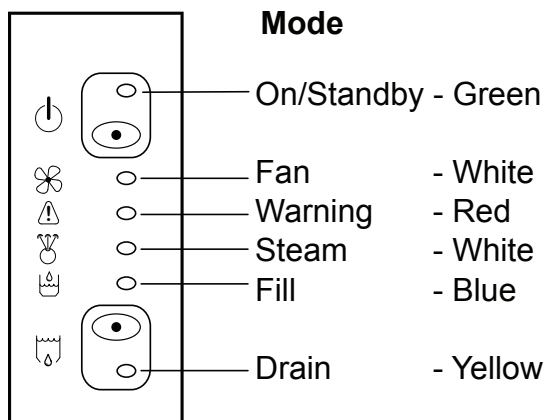





Fig. 5a

5.2 The ACU-STEAM humidistat also has two pilot lights to indicate the current status. The green light is lit when the humidistat is demanding for humidity, thus activating the boiling cycle. The red light indicates a warning and reproduces the same warning code as the red light on the humidifier control panel. If ever the red light is lit or flashing on the humidistat, you know immediately that the humidifier needs attention.

<u>Display</u>	<u>Status</u>	<u>Description</u>
 On/Standby Green light	OFF Blinking ON	The humidifier has no power – Breaker is OFF. The humidifier has power, but is in standby mode. The humidifier has power and is functional. Press to put the humidifier in standby mode. The green light is blinking. Press and keep depressed 3 seconds to power or reset the humidifier. The green light is ON.
 White button		
 Fan White light	ON	The fan control is activated.

**Warning**

Red light

ON

An abnormal condition occurred.

Please refer to the error code table in Section 7.

**Steam**

White light

ON

The humidifier is heating water to produce steam.

**Filling cycle**

Blue light

ON

The electric water valve is open thus filling the humidifier.

**Draining cycle**

Yellow light

ON

The humidifier is in draining mode.



White button

Not active on residential models.

6. What To Do if a Malfunction Occurs

6.1 Shut the main power OFF and restart the humidifier to see if the error code (flashing red light) disappears.

6.2 If you see a water leak, follow the water supply tube and close the valve installed on the water pipe located near the humidifier.

6.3 Please refer to the error code table to identify the possible cause of the malfunction and the actions that you can take.

6.4 Should the problem persist, please call your service company for they are the best qualified to help you. Describe the problem to them and mention the error code you observed on the front panel. They may be able to help you solve the problem over the phone. If not, they can call our technical service department.

6.5 Should you attempt to look at the unit yourself, please apply all appropriate safety measures. - Shut the main power OFF and ***wait for the unit to cool before you open it.***

7. Description of Error Codes

Number of flashes of the red light	Error Description	Humidifier Status	Actions to be Taken by the Technician	Reset
OFF	No error	The humidifier is working fine	None	
Countinuous ON	The flood sensor under the tank senses water in the pan.	Humidifier immediately suspends the ongoing operation. Heating elements and supply valve are switched off. The power green light is OFF.	Turn power off. Check for leaks around the tank clamp, SW valve and drain tube. Make sure tank arrows align and gasket is sealing properly.	Automatic Reset when Overflow pan dries up.
1	The two water level sensors are miswired or do not read the water level properly.	Humidifier attempts to operate, then stops because of wrong information from water level sensors. The power green light is blinking.	Turn power off. Clean or replace HLS or LLS water sensors. Check for proper wiring of HLS and LLS sensors.	Automatic Reset when switching main power ON
3	Inadequate water supply and/or marginal drainage. The supply valve was open for more than 6 minutes.	Humidifier immediately suspends the ongoing operation. Heating elements and supply valve are switched off. The power green light is ON.	Turn power off. Check SW valve circuit for 24V DC at the valve. Refer to manual (p. 20) and check for proper drain installation. Make sure SW shut-off valve is open, SW valve is responding and SW tube is clear of debris or else replace drain hose.	Automatic Reset after 5 min. or tuning main power on and off.
4	Inadequate drainage. The tank did not drain or the draining cycle is too long.	Humidifier immediately suspends the ongoing operation. Heating elements and supply valve are switched off. The power green light is blinking.	Turn power off. Check for proper drain setup by referring to manual (p. 20). Check and clean tank, SS siphon tube and silicon drain tube if necessary.	Automatic Reset when switching main power ON
 5	Fan not running.	Humidifier immediately suspends the ongoing operation. The unit goes back to normal operation as soon as the error condition disappears. The power green light is blinking.	Check if the fan motor is running. Turn power off and call a service technician.	Automatic Reset when error conditions disappear
ACU=STEAM 5	The air pressure switch does not detect enough air pressure.	Humidifier immediately suspends the ongoing operation. The unit goes back to normal operation as soon as the error condition disappears. The power green light is ON.	Check if the FF motor is running. If not, turn FF to continuous operation. Check flow sensor (pitot tube) in duct for blockage, then make sure plastic tube is connected properly from flow sensor to PD switch under PC board in unit (see manual). Change furnace filter if needed.	Automatic Reset when error conditions disappear
6	Temperature inside the tank exceeded the high temperature cut-out setting.	The high temperature cut-out has tripped. The humidifier immediately suspends the ongoing operation. Heating elements and supply valve are switched off. The power green light is blinking.	Turn power off. This is a serious condition and will likely require assistance from a service technician. Call 1-800-336-9130.	After pushing on the thermal cut-out button, automatic reset when switching main power ON

Legend: SS = stainless steel, SW = supply water, HLS = high level sensor, LLS = low level sensor

8. Maintenance

WARNING : The water tank and its contents can become *extremely hot*. Please be careful before proceeding.

As with any evaporative water device, some minerals normally dissolve in the tank water will create varying degrees of deposits inside the tank. Even though the unit drains and cleans itself during normal operation, it will require a minimum annual maintenance check (see sections 8.5 through 8.8) to assure all humidifier functions and components are operating properly.

8.1 Drain the water from the tank. Most of the time there will be water in the tank even when the humidifier is in standby mode since it only drains once per set amount of steam cycles (see section 18.5 for drain cycle settings). First turn down the humidistat to avoid a steam cycle. Please note that when using an ACU-STEAM electronic humidistat, if the relative humidity is extremely low the humidifier may still run with the knob at the minimum setting because of a range limiter inside the cover. If this occurs you will need to remove the humidistat cover by pulling it off and turning the knob completely counter-clockwise. The main power to the humidifier (the breaker at the main panel, not the power button on the unit) needs to be turned off and then back on. Once the power is reset the unit will start filling with water (blue LED will light) and keep filling until draining starts (yellow LED). This process can take a number of minutes. Once draining has completed, turn the main power off. There should be approximately one inch of water in the tank. **Wait a few minutes or until the unit has cooled before proceeding with the following steps.**

8.2 After draining the tank, **TURN THE MAIN POWER OFF.**

8.3 Remove the cover by turning the 1/4 turn screw to the left.

8.4 You do not have to remove the plastic tube attached to the bottom of the pan. Remove the overflow pan from the unit by lifting the front of the pan off the screw and pulling it towards you, slightly loosen the front screw if necessary. Please see Fig. 8a. Remove the main drain tube from the rigid drain pipe attached to the wall and check that the tube is clean and clear from deposits.

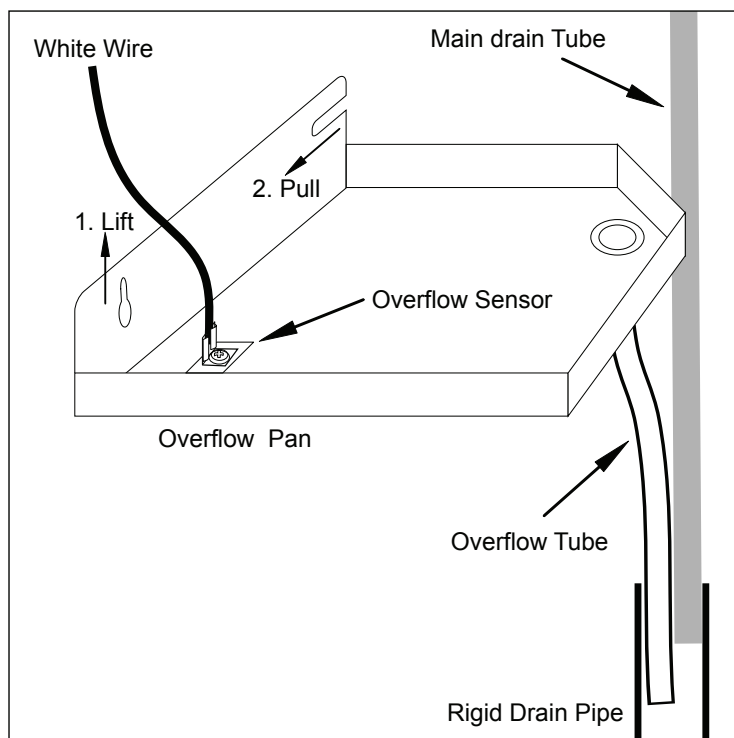

Fig. 8a

8.5 **CAUTION:** Check that the water tank is not too hot to handle. Unfasten the latch around the water tank

and remove the tank bottom from the main body of the tank vessel by pulling it down carefully in a twisting motion. Reminder: there should be a small amount of water in the tank. After you remove the tank, clean the round o-ring gasket, but don't discard it.

NOTE : *This round gasket is mandatory and the tank will not seal properly without it, likely resulting in a water leak.*

8.6 There will be varying degrees of scale on the tank bottom/sidewalls and internal components which is a normal byproduct of boiling water containing minerals. Simply discard the scale from the bottom of the tank, leaving the scale on the tank sidewalls and elements (it will not adversely affect the operation of the unit). Clean the scale from the bottoms of the stainless steel water discharge and water supply tubes using a cleaning product designed to remove scale, lime or calcium to enable unrestricted water flow. If scale is excessive, affecting the flow of water replace the drain tube and sensors when necessary; these replacement parts are included in a maintenance kit available from your installing contractor.

8.7 Once completed, reinstall the o-ring gasket around the bottom tank collar. Please see Fig. 8b. Align the two arrows located at the front of the tank and the fixed part while lifting the tank in place. Please see Fig. 8c. Apply even pressure to secure the tank properly in the tank cover. Then close the latch holding the tank in position. The clamp should close with minimal pressure. Verify that the o-ring gasket and tank are seated properly by checking for leaks when re-starting the humidifier.

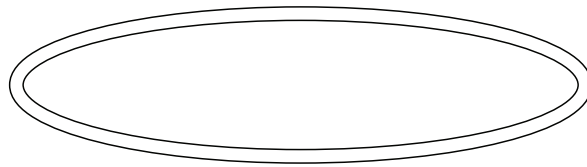

Fig. 8b

8.8 Put the overflow pan under the tank by sliding the slot on the back screw and hooking the key hole on the front screw.

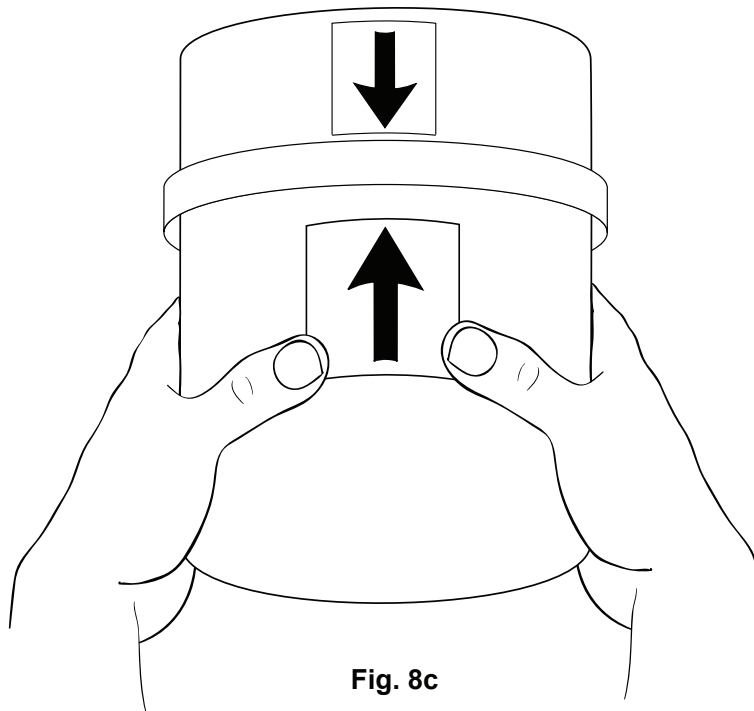

Fig. 8c

8.9 Put the cover back on the humidifier and lock it with the quarter-turn screw.

8.10 The water filter (Part #STM076 in Section 16.1) has a lifespan of 6 to 12 months and should be replaced once a year.

8.11 When finished, turn the main power back **“ON”**.

9. Preventative Maintenance

9.1 In order to avoid problems due to accumulation of deposits, we suggest that you replace the silicone drain tube and the low and high water level sensors at least once every 2 years. We also suggest you replace the round o-ring gasket around the tank. All these components are available in a kit. Contact your service company for more information.

9.2 To prepare for the Summer Season

- Perform a complete maintenance as described in section 8
- Shut the main power **OFF**
- Close the water supply valve
- Dry the inside of the tank

10. Warranty

10.1 Thermolec Ltd. warrants against defects **for a period of two (2) years** from the date of installation. An Extended Limited Warranty coverage applies to the following components: **10 years on the element and 5 years on the tank.**

10.2 Any claim under warranty shall be considered only if the product has been properly installed, by a certified technician, and operated in accordance with Thermolec's written instructions.

10.3 Any misuse of the steam humidifier or any repair by persons other than a certified technician, carried out without Thermolec's written consent, voids the warranty.

10.4 All defective parts must be claimed within the warranty coverage period and shall be replaced at no charge (transport included) by Thermolec. Thermolec does not cover the labor costs to execute the said repairs.

10.5 Thermolec will not be held responsible for accidental or consequential damages, nor for operational delays caused by the replacement of said steam humidifier.

Thermolec Ltd

2060 Lucien-Thimens St. Montreal, QC, H4R 1L1

Tel : 514-336-9130 Fax : 514-336-3270

Web site : www.thermolec.com

Help line for technical assistance during business hours

Monday to Friday, 8:30am to 5:00 pm (Eastern Time)

1-800-336-9130

Detailed Instructions for the Contractor

11. Unpacking the Unit

11.1 Contents

Please inspect the carton's contents and report any missing parts or damage immediately.

- 1 ea Humidifier
- 1 ea Instruction and maintenance manual

- 1 ea Steam hose (4 feet long x 1 inch I.D.) / 2 ea Steam hoses for Acu-15U
- 1 ea Steam diffuser (stub for Acu-5 and 16" for Acu-10) / 2x 16" diffuser for Acu-15
- 1 ea Pressure Differential Switch (mounted inside cabinet)

ACU≅STEAM

- 1 ea fan housing
- 1 ea plastic faceplate
- 1 ea Main siphon tube (32" long – already installed and coiled inside the unit)
- 1 ea Steam hose (2 feet long x 1 inch I.D.)

Split Steam

- 1 Plastic bag containing installation material and hardware as follows:
 - 2 ea Adjustable hose clips for the steam hose / 4 clips for Acu-15U
 - 1 ea Small bag - KIT #10S
 - 1 ea Water supply tube (1/4" dia.)
 - 1 ea Overflow tube for the overflow pan (7/16" dia.)
 - 1 ea Water Filter

- 1 ea Pitot tube with plastic tube (5/16" dia. x 72" long)

ACU≅STEAM

NOTE : The electronic humidistat and the outdoor reset sensor are optional. The humidistat can be either wall type (RH) or duct type (DH).

11.2 Water Tank Detailed View. Please see Fig.11a.

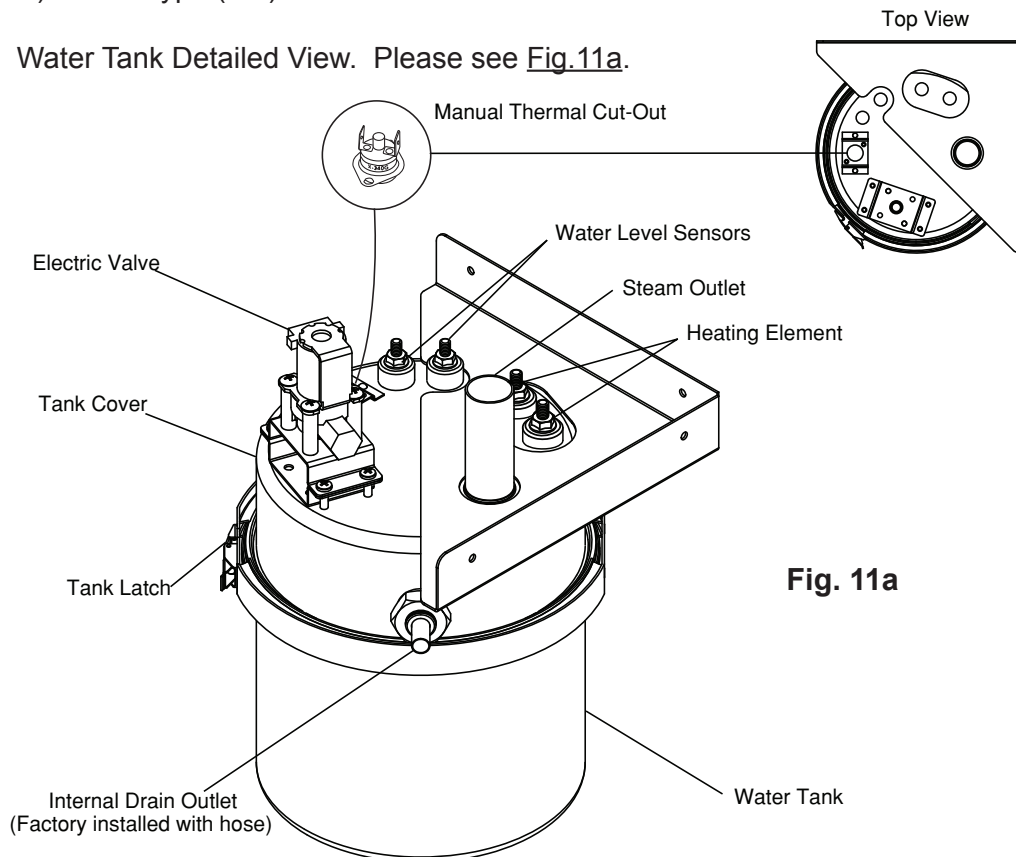

Fig. 11a

CONTRACTOR

12. Dimensions and Available Models

12.1 Humidifier dimensions

Fig. 12a

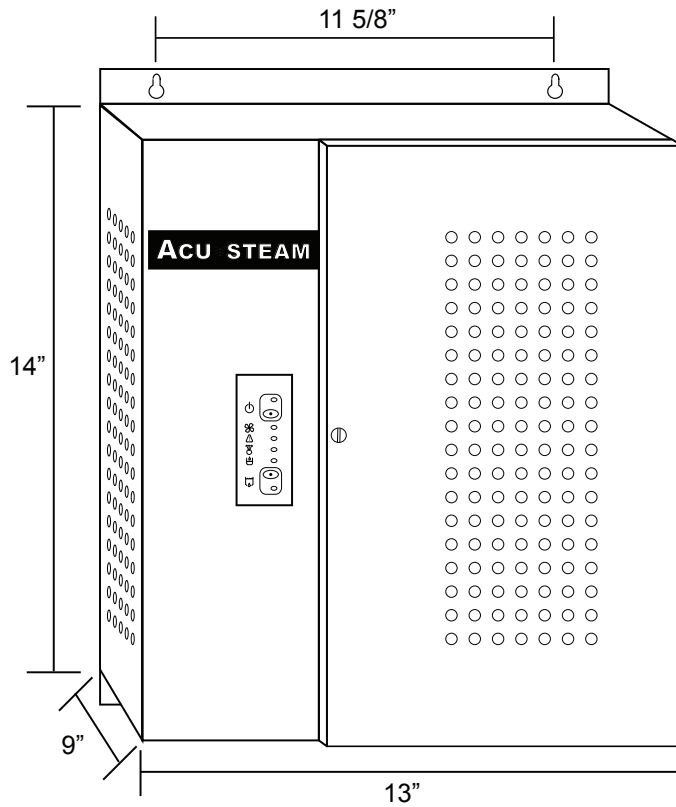

12.2 Available models

Fig. 12b



Model	Capacity Lbs/Hr (Kg/Hr)	Power (Kw)	Voltage (V)	Current (A)
Acu-5-SP	4.8 (2.2)	1.5	120	12.5
Acu-8-SP	7.7 (3.5)	2.4	240	10

ACU≈STEAM

Model	Capacity Lbs/Hr (Kg/Hr)	Power (Kw)	Voltage (V)	Current (A)
Acu-5	4.8 (2.2)	1.5	120	12.5
Acu-10	9.6 (4.4)	3	240	12.5
Acu-15	12.8 (5.9)	4	240	16.6

CONTRACTOR

13. Detailed View and Wiring

View of the top of the unit.

Fig. 13a

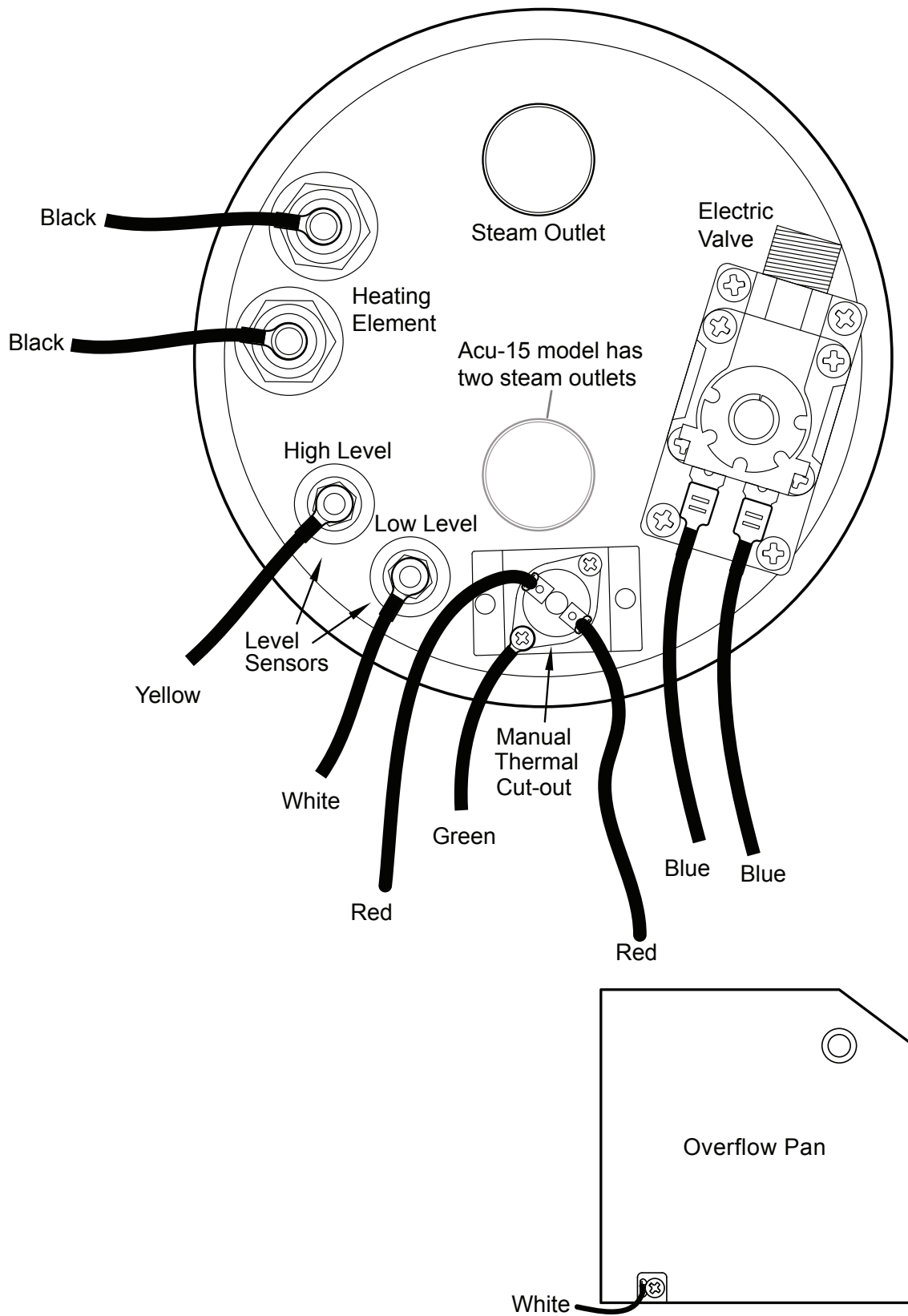

CONTRACTOR

View and list of the wire harness by color and function. Please see Fig. 13b & Fig. 13c.

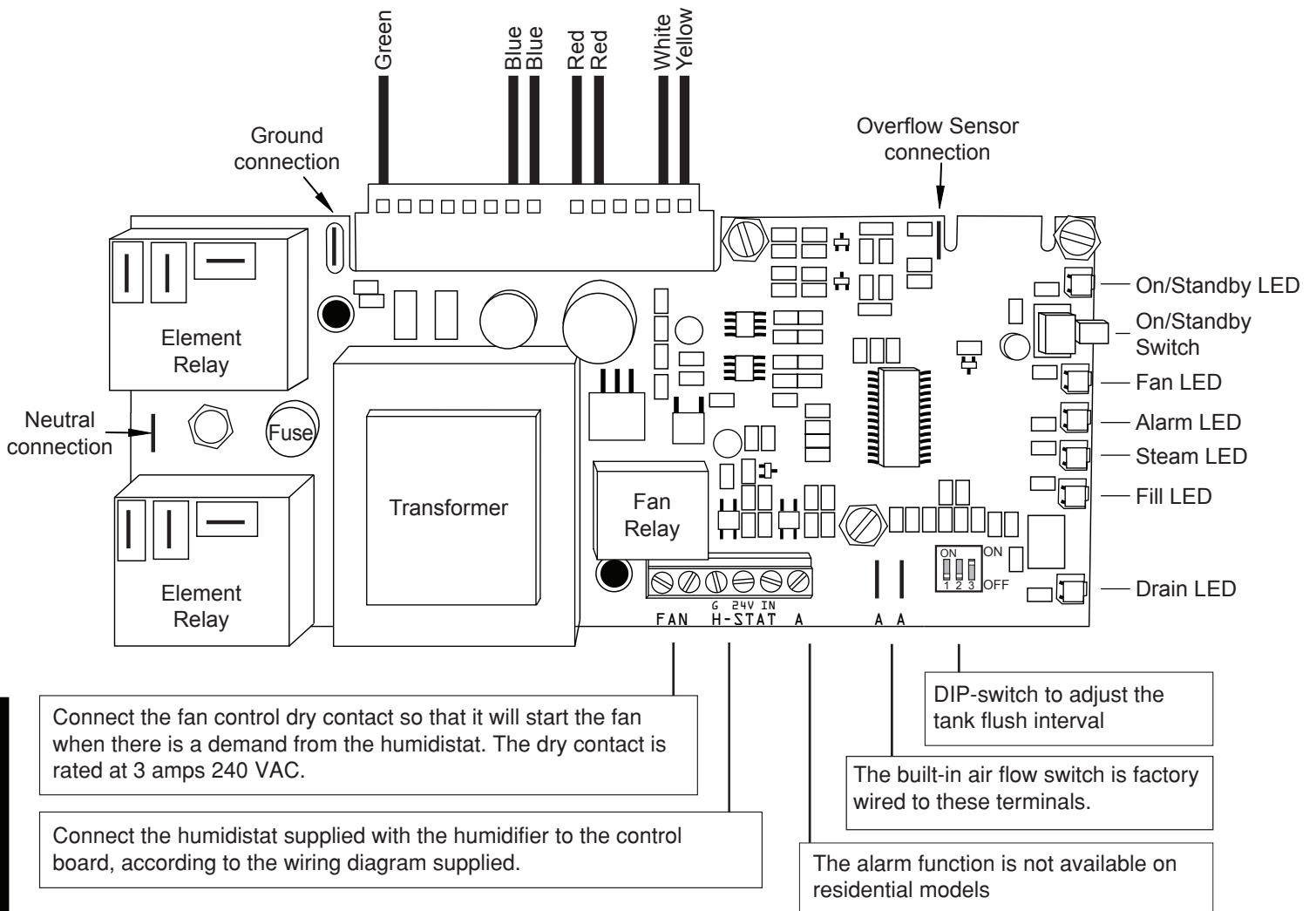

Fig 13b

Description of Wire Harness		
Color	Function	Connected to
Green	Grounds the electronic board to the tank for the level sensors	Bracket of the high limit cut-out
Blue/Blue Pair	Powers the electric valve with 24 VDC	Electric Valve
Red/Red Pair	Overheat signal	High-Limit Cut-Out
White	Reads the low water level	Low Level Sensor
Yellow	Reads the high water level	High Level Sensor

Fig. 13c

Note: Please read sections 14 and 15 before proceeding.

14. Installing the Steam Diffuser and the Steam Hose

14.1 Proper installation of the diffuser and steam hose is critical for the trouble-free operation of the humidifier. Please find an accessible location on the duct and make sure you have a **minimum length of 35"** of straight duct downstream (without elbows or other obstructions on which the steam could condensate), to allow the steam to disperse easily into the airflow. Once a suitable location has been found make a 1 1/8" middle insertion hole in the warm air duct for the steam diffuser. For a horizontal duct, make the 1 1/8" hole in the lower third of the duct height. Please see [Fig. 14a](#). For a vertical duct, make the 1 1/8" hole in the middle of the duct. Please see [Fig. 14b](#).

Note: For High Velocity systems, the diffuser should be installed in the RETURN and **not** the warm air duct.

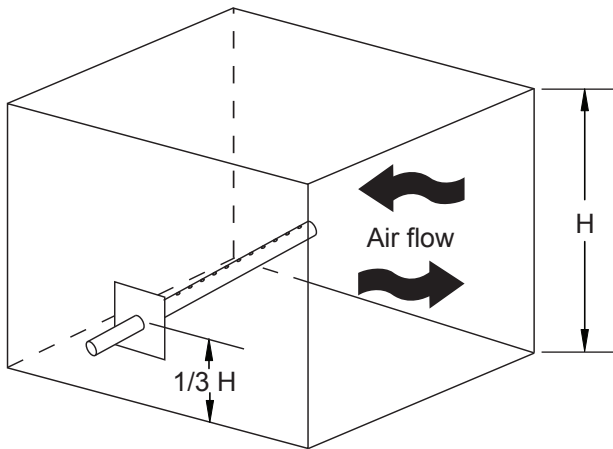

Fig. 14a HORIZONTAL DUCT

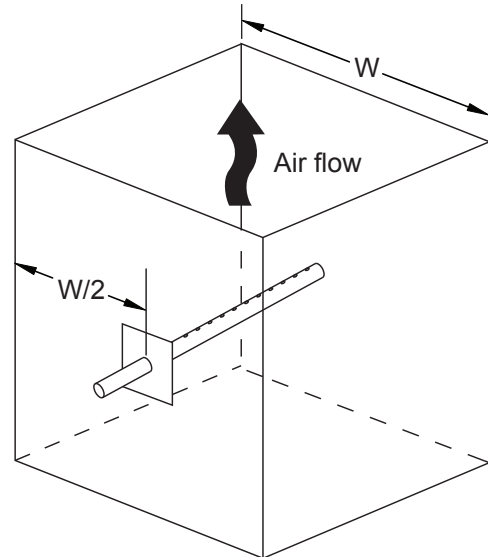

Fig. 14b VERTICAL DUCT

Warning : Before installing anything on a duct, always check that you are not about to cut or drill into an air conditioning coil or electrical accessories.

14.2 Insert diffuser in duct and align arrow to point up. Fasten the steam diffuser to the duct using four #8 x 1/2" screws provided in Kit #10S. Make sure the holes on the steam diffuser, where the steam exits from, are pointing up. Please see [Fig. 14c](#).

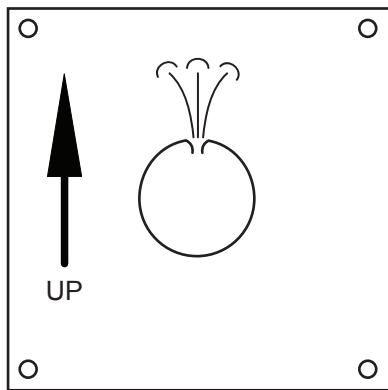

Fig. 14c

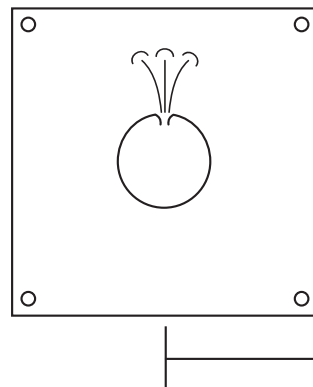
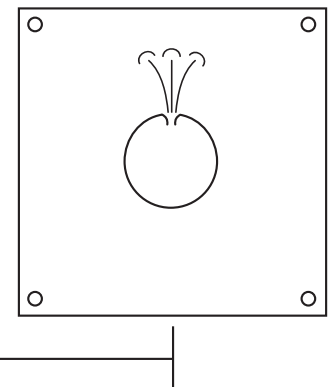
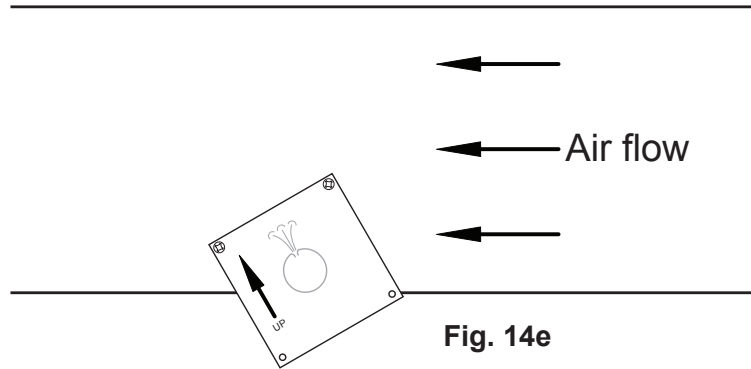

Fig. 14d



Note: Acu-15 models are supplied with two diffusers, hoses and clamps, if there are dual ducts install one diffuser in each duct with equal length of hose on each. When installing in the same duct keep a distance of 6" to 12" between diffusers. Please see [Fig. 14d](#).

IMPORTANT: For horizontal ducts that are only 8" to 10" inch high, install the diffuser at the very bottom of the duct with only the top two screws and rotate approximately 30° away from the airflow to avoid condensation forming at the top of the duct. Please see Fig. 14e.



14.3 Install one end of the steam hose onto the steam diffuser using a hose clamp and tighten it.

14.4 After installing the humidifier (Section 15) use the second supplied hose clamp, to install the other end of the steam hose (4 feet long) onto the steam outlet on the top of the water tank and tighten it.

Never try to reduce the diameter of the steam hose or any added rigid piping. It has to be the same as the diameter of the humidifier top steam outlet fitting. The steam must flow without obstruction. A four foot steam hose extension is available if the supplied steam hose is not long enough. Copper pipe with a diameter of one inch may be used to reach distances up to 20 feet with a continuous slope back down to the unit.

WARNING : Do not let the hose sag when it is connected to the duct. Please see Fig. 14f.

A sufficient slope with ***no horizontal section is mandatory*** to allow any condensation to flow back naturally to the water tank. Please see Fig. 14g. If condensation water accumulates in the hose, the steam will not be able to escape normally through the diffuser and will lead to a malfunction of the humidifier. Please keep in mind that the hose will soften when heated and will have a tendency to sag.

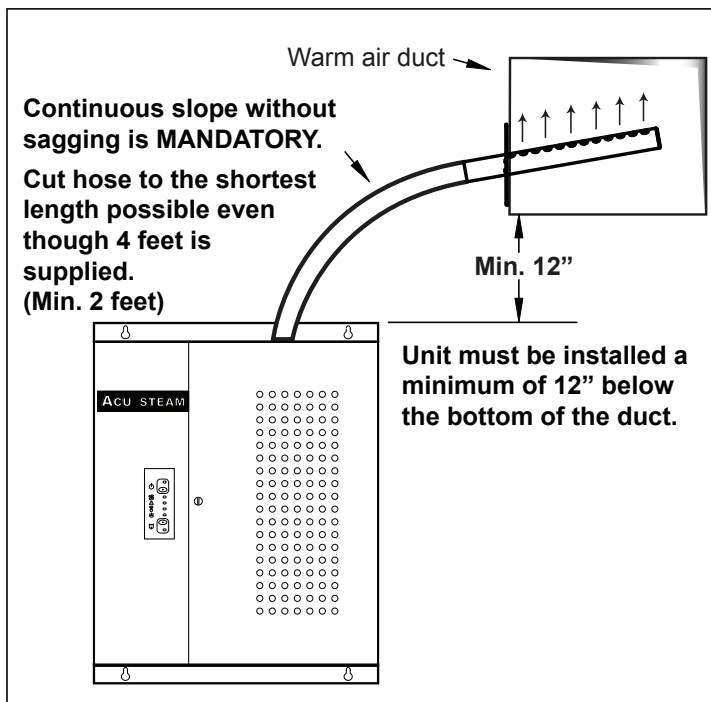

IDEAL
Fig. 14g

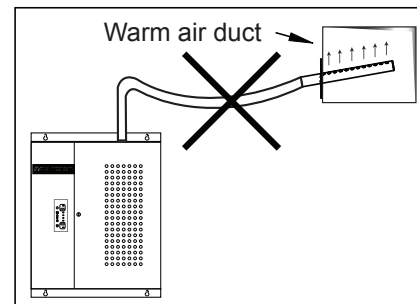

WRONG
Fig. 14f

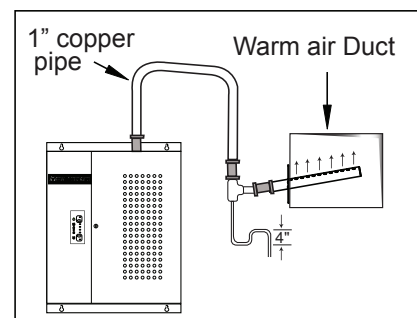

CORRECT
Fig. 14h

NOTE : If it is not possible to get enough slope for the condensation to return properly to the water tank, then an S-shaped steam trap (not supplied) must be installed at the lowest point of the steam hose. This steam trap hose should have a minimum height of 4". Please see Fig. 14h.

CONTRACTOR

Note: Please read sections 14 and 15 before proceeding.

14. Installing the Steam Hose and the Fan module

The fan supplies up to 80 CFM of airflow to distribute the steam.

NOTE: This unit is supplied with 2 feet of steam hose and therefore the distance between the fan module and steam generator should be less than two feet, see figure 14a. Longer hoses at a length of 4 feet are available from Thermolec. For distances up to 12 feet, a section of insulated copper pipe can be connected between two pieces of steam hose.

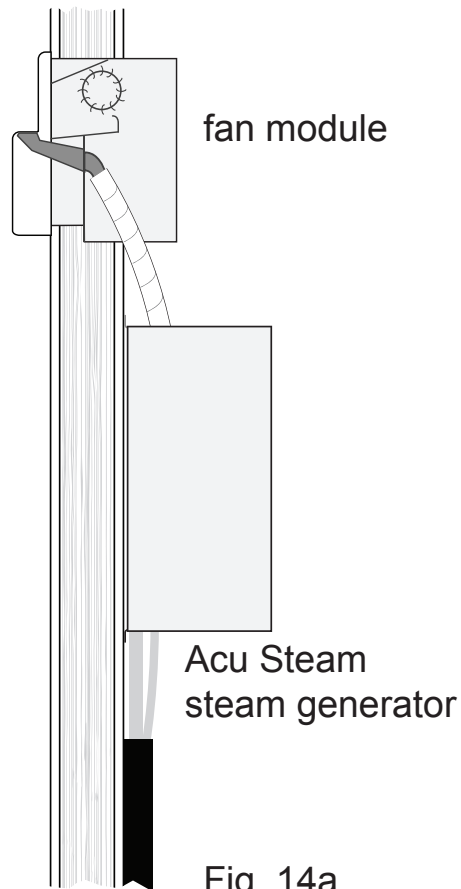

Fig. 14a

14.1 The fan distribution module must have a minimum clearance of 2 feet from the ceiling or adjacent walls and a minimum clearance of 3 feet in front of the faceplate. With these distances in mind measure a rectangle of 9 1/8" wide by 6 1/4" high. The rectangle needs to be level with respect to the floor. Drill a small pilot hole through each corner from the faceplate wall and through the other side of the wall. With a saw cut out the rectangle from corner to corner. Take care not to drill through or cut any electrical wires or plumbing. Please see figure 14b.

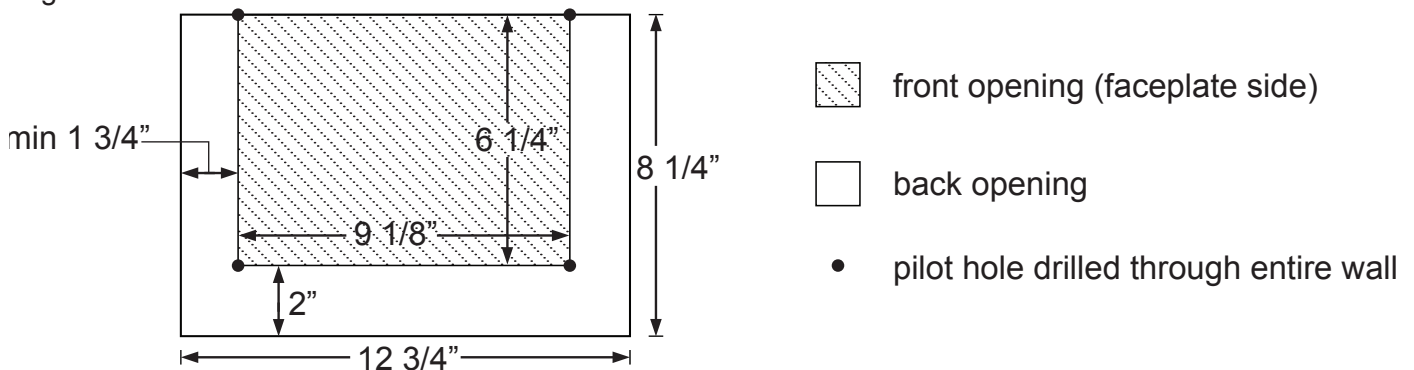

Fig. 14b

14.2 The opening at the back of the wall must be at least 1 3/4" wider on each side, 2" lower at the bottom and flush with the top of the 4 pilot holes. Mark these points to make a larger rectangle and cut it out.

14.3 Attached the mounting flanges to the fan module with the screws provided but do not tighten the screws so that the flanges are able to slide along the slots. Slide the fan module into the wall until the front edge is flush with the wall, figure 14c. Tighten the screws holding the tabs so that the front remains flush with the wall. Level the unit and screw the flanges to the wall.

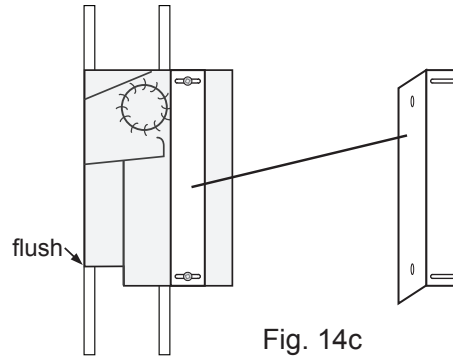

Fig. 14c

14.4 Push the faceplate on the front until it snaps into place. Check to be sure that the faceplate completely covers the opening in the wall.

Once the steam generator is installed, connect the steam hose between the difuser in the fan module and the tank in the steam generator with the clamps provided and wire the fan module according to the wiring diagram near the end of this booklet.

CONTRACTOR

15. Installing the Humidifier

For ease of service, keep a minimum space of 24" in front of the unit.

15.1 Remove both covers by first turning the 1/4 turn screw to the left and swing open the tank cover and unhook it. Then unscrew the two screws holding the electrical cover and pull it towards you.

15.2 Remove the white wire connected on the water pan at the bottom of the unit. This is the overflow sensor.

15.3 Remove the overflow pan by lifting the front off its holding screw and pull towards you. Do not remove those screws from the humidifier middle wall.

15.4 The humidifier must be installed on a vertical flat surface (i.e. wall). Because of the length of the steam hose supplied, select the location of the unit as **close as possible** within a maximum of 2 feet of the diffuser. Please see [Fig. 15.a](#) for necessary clearances around the humidifier.

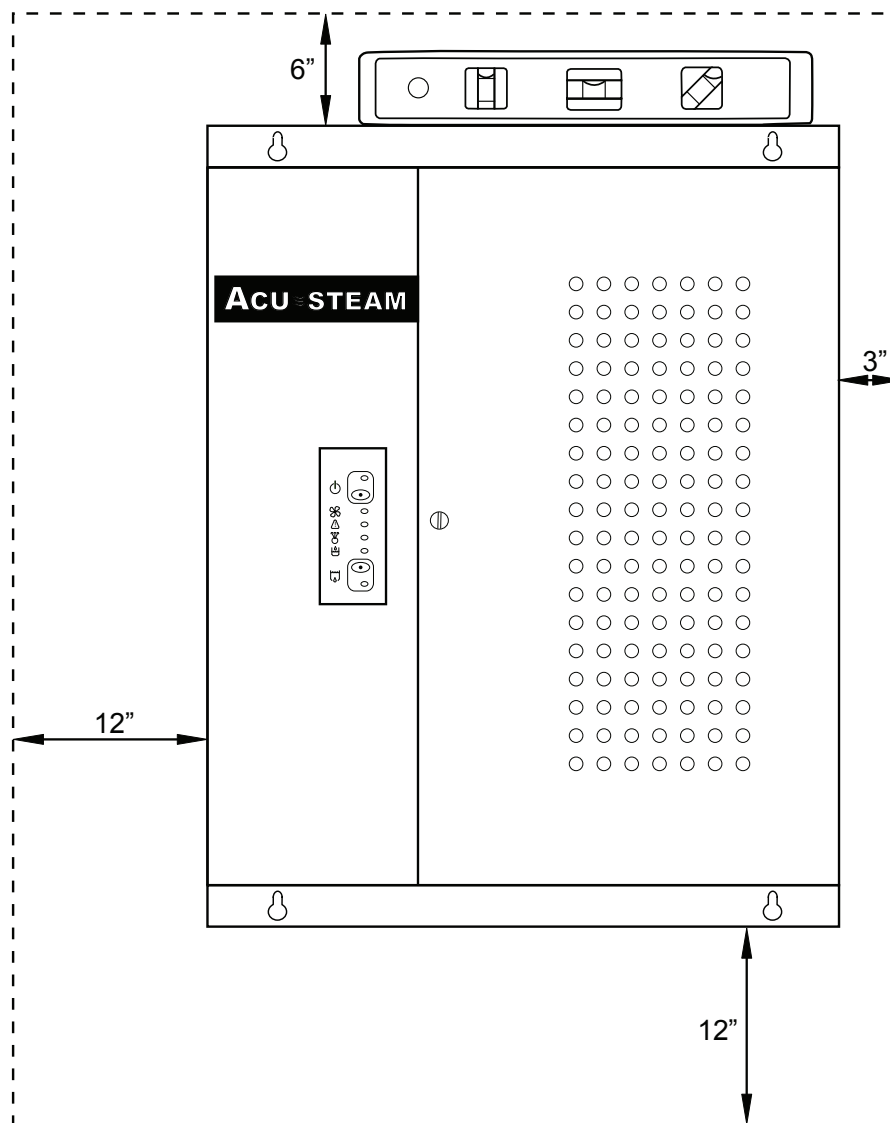
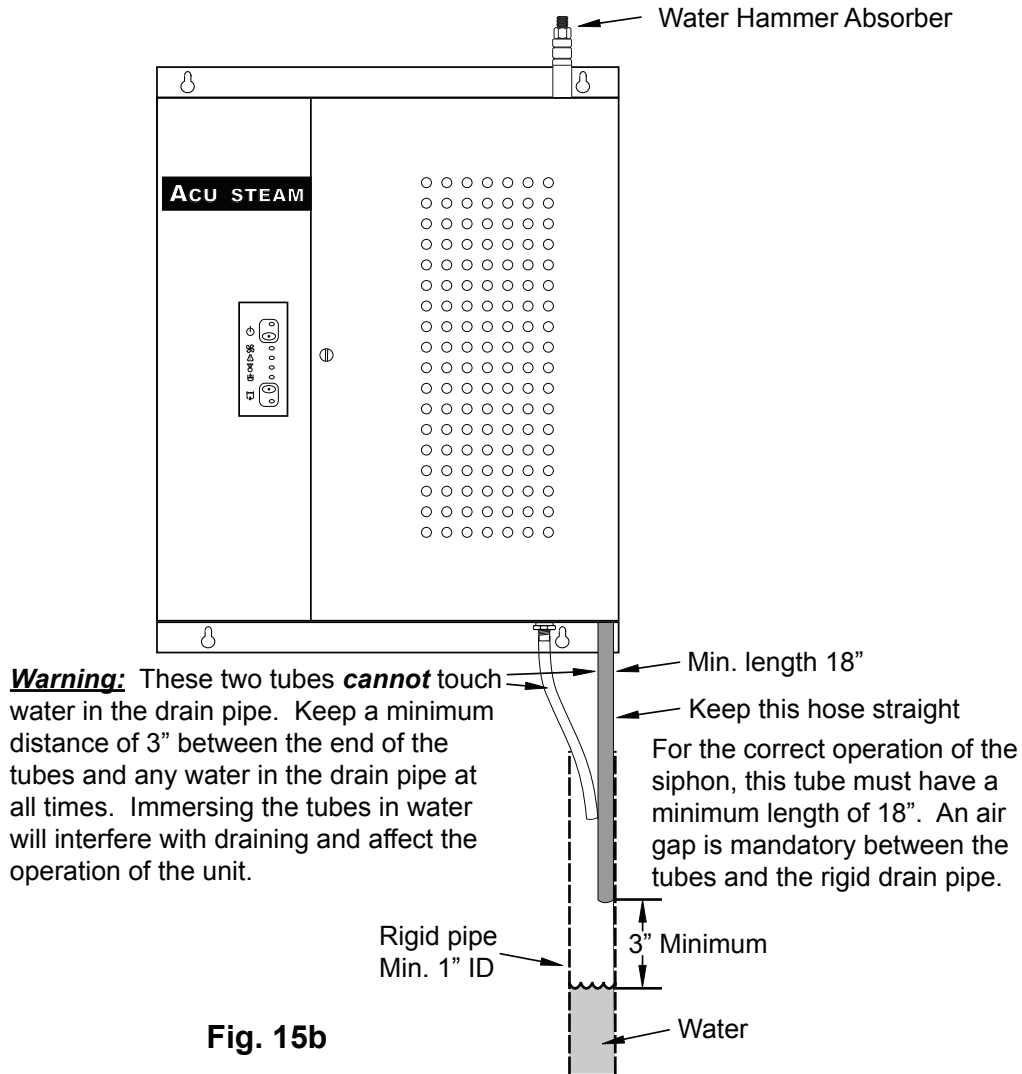

Fig. 15a

15.5 A rigid drain pipe has to be installed under the unit and connected to the main house drain. We recommend a 1" minimum I.D. tube or standard 1-1/2" I.D. ABS plumbing tube to do the installation. Please also install a siphon (P-trap) with a drain cap, if required. The two flexible tubes (main drain and overflow) coming from the humidifier and which will be inserted in the rigid pipe, require a minimum free vertical length of 18" below the cabinet. It is very important to leave an air gap between the rigid pipe and the tubes to allow the siphon to function properly. The flexible tubes cannot touch any water contained in the drain pipe. Please see Fig. 15b.

NOTE: For locations without a drain, the tubes can drain into a condensate pump with a minimum flow of 65 GPH @ 1FT / 15FT max.

CONTRACTOR



15.6 Since the unit is equipped with water level sensors, it is important to install it level from left to right and from back to front.

15.7 Draw a level horizontal line on the wall and install two screws (# 8 minimum) spaced at 11-5/8" from each other to hook the humidifier on the wall, then install two screws at the bottom of the unit and tighten them partially.

15.8 Level the unit and tighten the four screws firmly.

NOTE: The tank holds approximately a half gallon of water and when mixed with cold water the humidifier will flush 1 to 1.5 gallons of water. The temperature of the water draining from the unit is approximately 140°F (60°C).

16. Installing the Water Supply and drain pan connections

Important Notes :

- Close the main water supply valve before beginning.
- We recommend installing a quarter of a turn shut off valve (not supplied) near the unit. This supply valve (not supplied) must be attached to a **cold** water pipe only, easily accessible from the Acu-Steam unit. Since the unit is draining hot water, **cold** water is added to reduce the temperature before sending the water to the drain.
- In case of hard water or water containing particles, we recommend installing a strainer in the water line to protect the solenoid valve. See section 1.1 for additional information and recommendations concerning water quality.

16.1 A water line filter is supplied and should be installed between the shut off valve and the water hammer absorber. It is strongly recommended to flush the supply water line for 30 seconds before connecting the filter. Simply push the tubing (plastic or copper) into the quick connect fitting until it bottoms out. Once the filter is connected it is recommended to flush the supply water through the filter for another 30 seconds. Please see [Fig. 16a](#).

16.2 At the end of the water hammer absorber, connect the water supply tube, using the same type of fitting used on the water supply valve. Tighten the compression nut, without stripping, with two wrenches, one to hold the water hammer end, and one to turn the compression nut. Please see [Fig. 16b](#).

NOTE : The brass sleeve supplied in kit #10S is to be used only if the plastic supply tube is replaced by a copper tube. Either system works with this humidifier, but only plastic tubing is supplied.

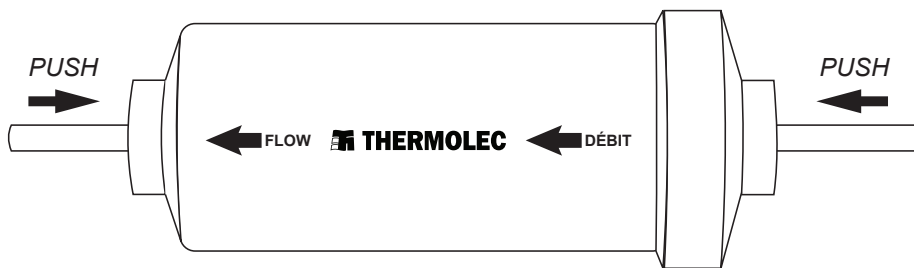

Fig. 16a

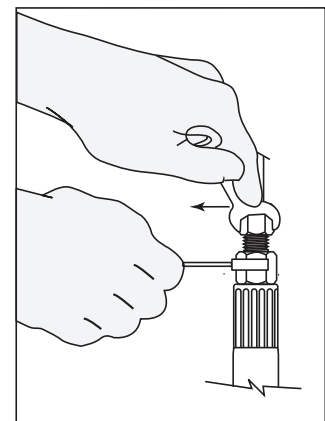

Fig. 16b

Keep the supply valve closed for now, you will open it during the start-up procedure.

16.3 Take the 5/16 dia. plastic tube and push one end on the connector located at the bottom of the overflow pan. Please see [Fig. 16c](#) and [Fig. 16d](#).

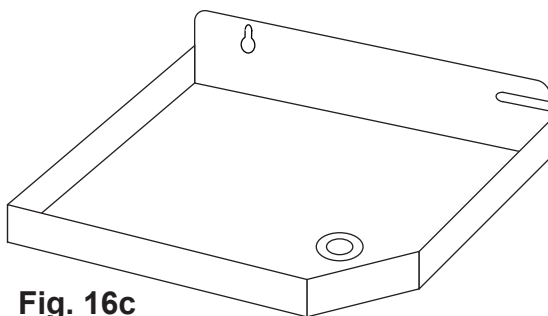

Fig. 16c

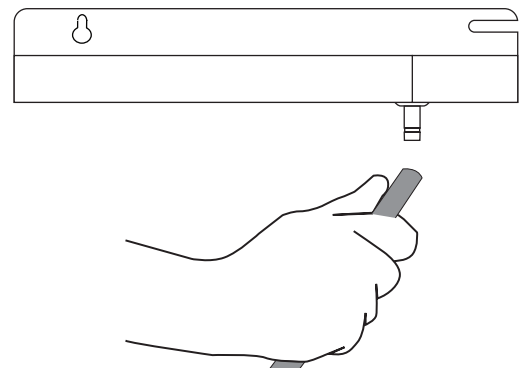

Fig. 16d

16.4 Cut the two drain tubes and insert them in the rigid pipe. Note that the main silicon **drain tube must have a minimum length of 18"** to allow the siphon to work properly. It is important to leave an air gap between the soft tubes and the rigid pipe.

16.5 Open the water supply valve (fully counter-clockwise) to bring water to the humidifier and let the water pressure enter the system.

16.6 Follow the water supply path completely and carefully check for leaks at the fittings.

17 Installing the Air Pressure Probe

17.1 The pressure probe (also called a Pitot tube) connected to the pressure differential switch inside the unit checks whether there is enough air pressure in the warm air duct to activate the humidifier.

17.2 The probe can be installed in either the warm air or cold air return duct, as close as possible to the humidifier, but before the steam diffuser. A 48" long plastic tube is supplied to connect the pressure probe to the humidifier.

Warning : Before installing anything on a duct, always check that you are not about to cut or drill into an air conditioning coil or electrical accessories.

17.3 Drill a hole 3/8" dia. in an accessible location in the air duct.

17.4 Insert the probe and fasten it's base to the duct using two sheet metal screws. The arrow visible on the probe flange indicates the air flow direction in the duct (i.e. the curved end of the probe has to face the air flow) Please see [Fig. 17a](#) and [Fig. 17b](#).

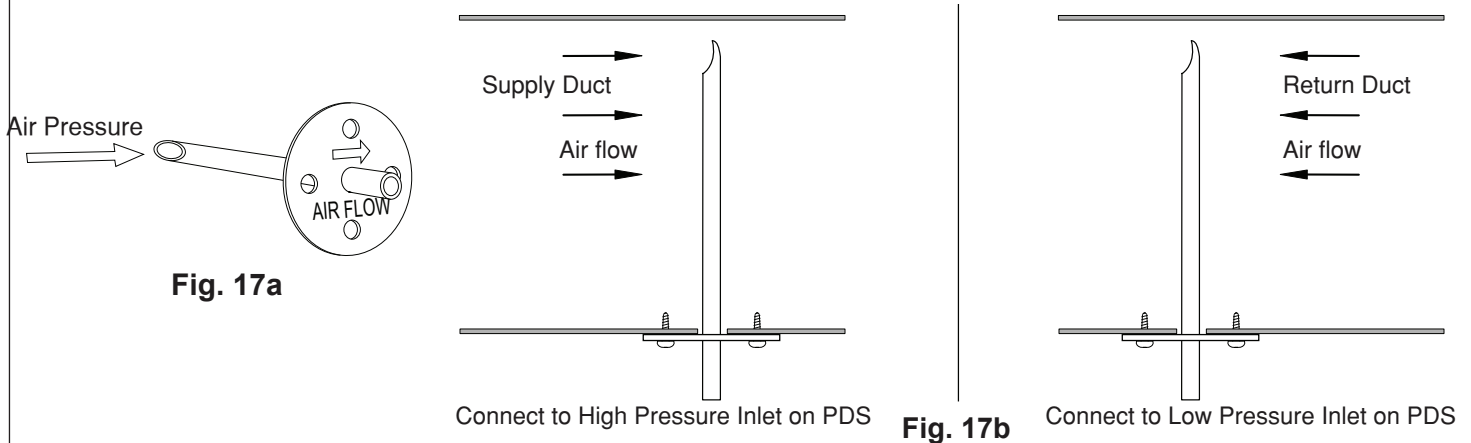

17.5 Push one end of the plastic tube onto the probe outlet. Slip the other end of the tube onto the High pressure inlet on the pressure differential switch. If the probe is installed in the return duct connect to the low pressure inlet instead. The PD Switch located below the electronic control board.

Recommended CFM per model:

Acu-5:	600 CFM
Acu-10:	1200 CFM
Acu-15:	1500 CFM

18. Making Electrical Connections

NOTE : All internal wiring is done at the factory. All external wiring shall be done by a qualified electrician and must conform to procedures, regulations and local codes.

18.1 A dedicated breaker in the main panel (or fused disconnect) must be installed.

18.2 Ensure that the wire size and protection equipment conform to the sizes required by the Electrical Code.

18.3 Wire according to the wiring diagram supplied in the cover of the unit.

18.4 Starting the fan is mandatory with this type of humidifier. The electronic controller board has a control relay that supplies a **dry contact** at the terminals marked "FAN" to start the furnace fan. The installer must use this contact to engage a relay that starts the furnace fan motor. Please refer to the furnace instruction manual to find the right wiring diagram. The standard rating of these contacts is 3A @ 240VAC or 6A @ 120VAC. Please do not exceed these ratings.

ACU=STEAM

18.4 Starting the fan is mandatory with this type of humidifier. The humidifier has a terminal block for Fan Power. The installer must use this connection to engage the fan motor. Please refer to the wiring diagram.

Split Steam

18.5 Adjusting the DIP switches, located on the lower right corner of the circuit board (see Fig 18a), will change how the humidifier determines automatic tank flushes. The humidifier will completely drain and refill with fresh water after a set number of "refill cycles". **Every time the unit replenishes the tank while producing steam is counted as one cycle.** The table below shows how to set the DIP switches in order to make the unit flush the tank at different intervals. To keep deposits in the tank to a minimum, by default the tank will flush every 30 cycles which equals approximately 5 hours of operation.

Switch numbers on DIP-switch				
1	2	3	Cycles Before Tank Flush	Water Hardness
OFF	OFF	OFF	180	Soft < 60 mg/L
ON	OFF	OFF	120	Moderate 60 - 120 mg/L
OFF	ON	OFF	60	Hard 120 - 180 mg/L
OFF	OFF	ON	30 (DEFAULT)	Very Hard > 180 mg/L

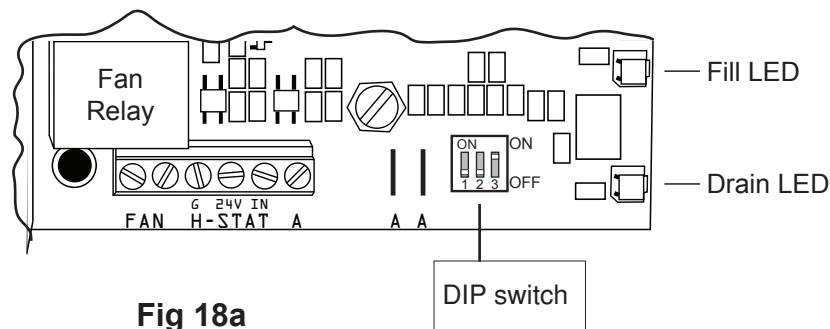

Fig 18a

CONTRACTOR

19. Installing and Connecting to a Humidistat

19.1 See wiring diagrams in section 21 for proper connection. When using an ACU-STEAM electronic humidistat with outdoor sensor please refer to the instructions included with the humidistat (see page 4, sections 4.1 through 4.5 explain the functions of the Acu-Steam wall and duct humidistats). If you decide to use a standard mechanical humidistat by others, connect the mechanical humidistat between the terminals marked GND (ground) & IN (input) on the humidifier electronic board.

20. Start-up and Test Procedure

- 20.1 Turn the breaker “ON” to supply power to the humidifier. The green light comes ON to confirm that the unit is ready to work.
- 20.2 Test of the On/Standby button. Press the white button once. The green light goes OFF then flashes, indicating that the unit is in standby mode but still powered. Press the white button again and keep it depressed for 3 seconds to power the humidifier. The green light will come ON, confirming that the unit is ready to work.
- 20.3 Turn the humidistat clockwise to create a demand for humidity.
- 20.4 The tank fills to the proper water level.
- 20.5 The fan control starts the fan to move the air as the humidifier starts boiling water and produces steam. If the fan cannot start, the humidifier suspends the ongoing operation. Please note that it may take a few minutes to bring the water to a boil. The steam exits the water tank through the steam outlet and steam hose.
- 20.6 The steam moves through the hose to the diffuser and is released into the air.
- 20.7 As water evaporates in the tank, the electric valve opens as needed to maintain the proper water level.
- 20.8 When the humidity reaches the desired level the humidifier stops producing steam. In order to eliminate the residues and keep the tank as clean as possible, the humidifier drains after a certain number of boiling – refill cycles. If there is still a demand from the humidistat after draining, the tank refills and starts to produce steam again.
- 20.9 When the humidistat is satisfied, the fan continues to run for a short period of time in order to clear the steam from the ducts.
- 20.10 When everything is working fine, put both covers back on the unit and attach them with the two screws (electrical cover) and by turning the 1/4 turn latch to the right (tank cover).
- 20.11 Sequence of Operation.

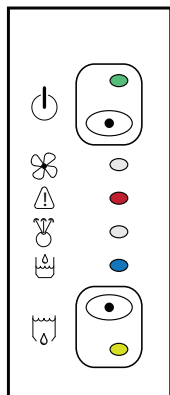

Power On	Draining Cycle		Filling Cycle	Boiling Cycle			
1	2	3	4	5	6	7	
Power On	Power Off						Power On
				Fan On		Fan On	
					Water Level		
	Water Level		Water Level			Water Level	
	Water Level	Water Level					
Up to 5 sec.	Up to 4 min.	Up to 2 min.	Up to 2 min.	Up to 5 sec.	Up to 12 min.	Up to 20 sec.	
	Up to 6 minutes total for drain cycle				1 Steam cycle* (see below)		

* The unit will repeat this cycle until the humidistat is satisfied or the selected number of cycles is reached before going to the draining cycle. If there is no more demand for humidity, the unit will automatically go on ready mode until the next demand. **If there is no demand for 7 days, the unit will flush and drain the tank.**

NOTE:

The Acu-Steam board has a memory that remembers the last sequence of operation when the power is turned off, hence the unit might start at step 2 or 3 when you put the power back on. Also, timings may slightly vary depending on the capacity of the unit (1.5 kW, 3 kW or 4 kW), the pressure of the water inlet and the quality of the water.

20.12 **Please don't forget to leave this instruction manual with the customer.**

21. Wiring diagrams

CONTRACTOR

IMPORTANT:
WIRE IN ACCORDANCE TO LOCAL & NATIONAL ELECTRIC CODES. READ CAREFULLY INSTALLATION INSTRUCTIONS BEFORE WIRING AND OPERATING.

LEGEND

- PC-1 -- PRINTED CIRCUIT BOARD
- M -- MANUAL RESET CUT-OUT 225°F
- PDS -- PRESSURE DIFFERENTIAL SWITCH
- K1 -- OPERATING RELAY
- K2 -- BACK-UP RELAY
- LLS -- LOW LEVEL SENSOR
- HLS -- HIGH LEVEL SENSOR
- V1 -- ELECTRIC VALVE 24 VDC
- T -- TRANSFORMER
- FS -- FLOOD SENSOR
- HE -- HEATING ELEMENT
- H-STAT -- ROOM OR DUCT HUMIDISTAT
- R -- FAN RELAY
- GND -- GROUND CONNECTION
- S-15 -- OUTDOOR SENSOR
- FU -- CONTROL FUSE

IMPORTANT:
SUIVRE LES CODES ELECTRIQUES NATIONAUX ET LOCAUX AINSI QUE LES INSTRUCTIONS CONTENUES DANS L'APPAREIL.

LEGENDE

- PC-1 -- CIRCUIT IMPRIME
- M -- SONDE THERMIQUE 225°F
- PDS -- A REENCLENCHEMENT MANUEL
- K1 -- INTERRUPTEUR A DIFFERENTIEL DE PRESSION
- K2 -- RELAIS DE FONCTIONNEMENT
- LLS -- RELAIS DE SECURITE
- HLS -- CAPTEUR DE BAS NIVEAU
- V1 -- CAPTEUR DE HAUT NIVEAU
- T -- VALVE ELECTRIQUE 24VDC
- FS -- TRANSFORMATEUR
- HE -- CAPTEUR DE DEBORDEMENT
- HE -- ELEMENT CHAUFFANT
- H-STAT -- HYGROSTAT DE PIECE
- R -- RELAIS DE VENTILATEUR
- GND -- PRISE DE TERRE
- S-15 -- CAPTEUR EXTERIEUR
- FU -- FUSIBLE DE CONTROLE

240V MODELS

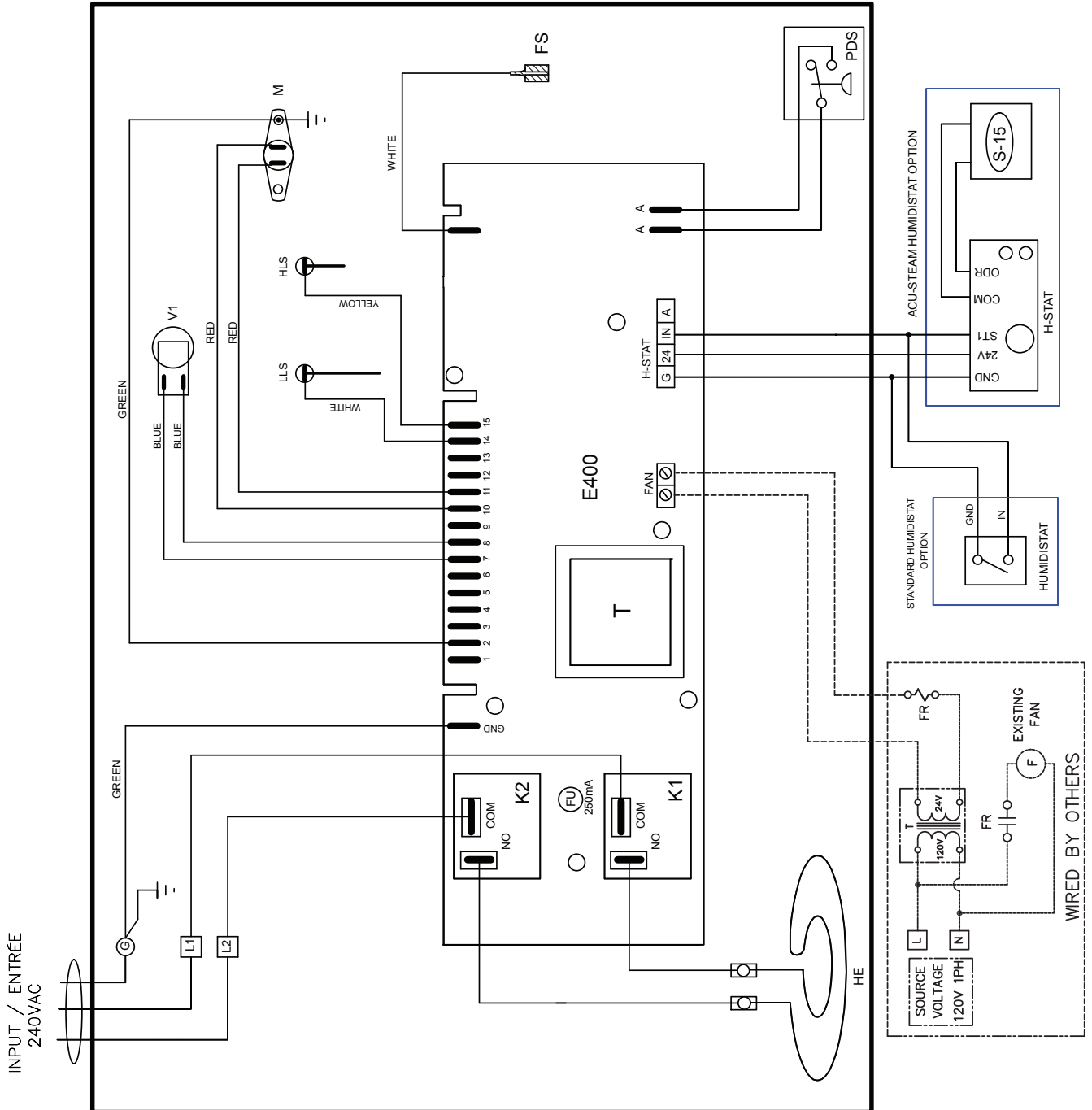

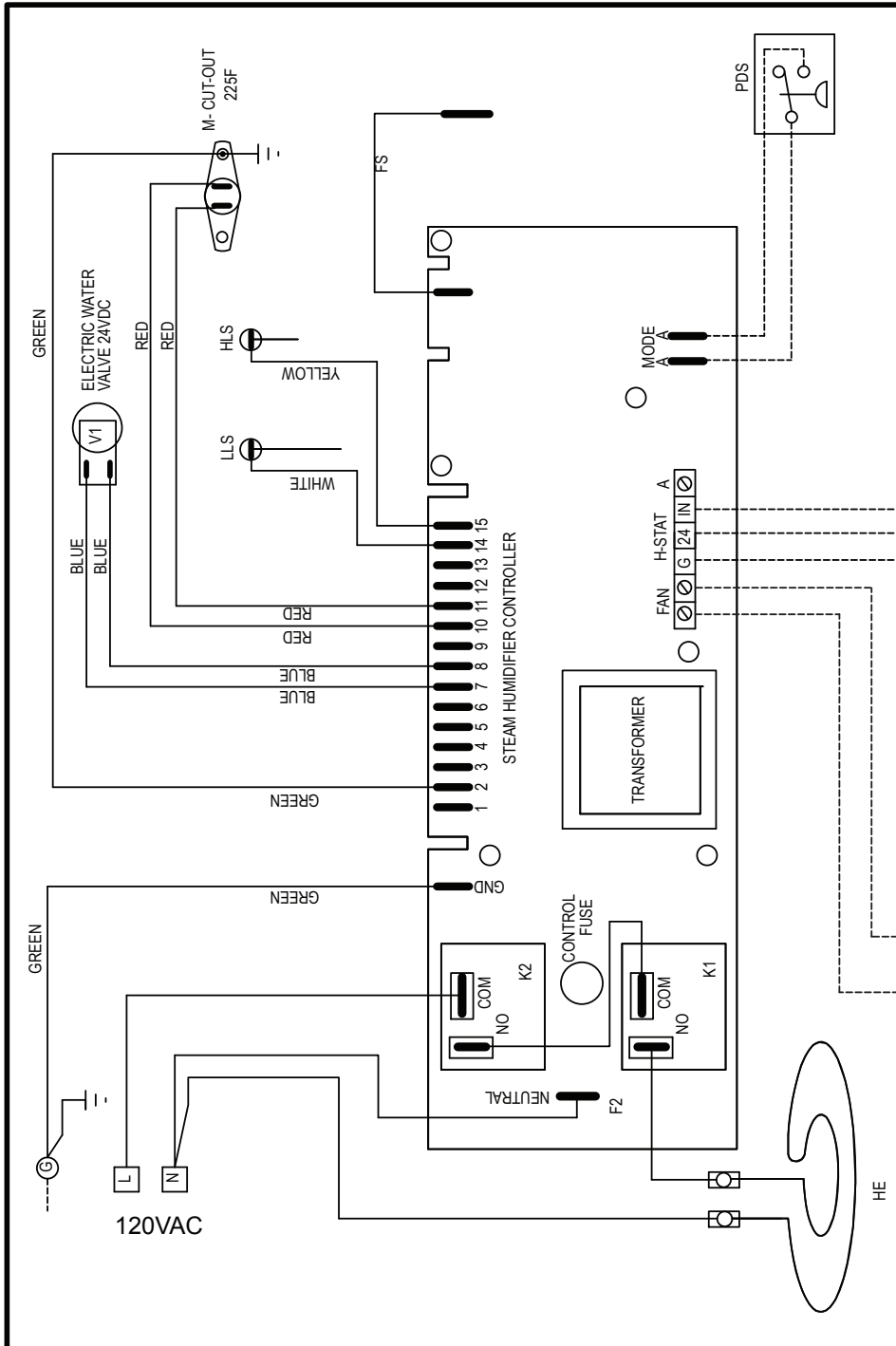

IMPORTANT:
 WIRE IN ACCORDANCE TO LOCAL & NATIONAL ELECTRIC
 CODES. READ CAREFULLY INSTALLATION INSTRUCTIONS
 BEFORE WIRING AND OPERATING.

LEGEND

- PC-1 - PRINTED CIRCUIT BOARD
- M - MANUAL RESET CUT-OUT
- PDS - PRESSURE DIFFERENTIAL SWITCH
- K1 - OPERATING RELAY
- K2 - BACK-UP RELAY TO THERMAL CUT-OUT
- LLS - LOW LEVEL SENSOR
- HLS - HIGH LEVEL SENSOR
- V1 - ELECTRIC VALVE 24 VDC
- T - TRANSFORMER
- FS - FLOOD SENSOR
- HE - HEATING ELEMENT
- H-STAT - ROOM OR DUCT HUMIDISTAT
- R - FAN RELAY
- GND - GROUND CONNECTION
- S-15 - OUTDOOR SENSOR

ACU-5 120V MODEL

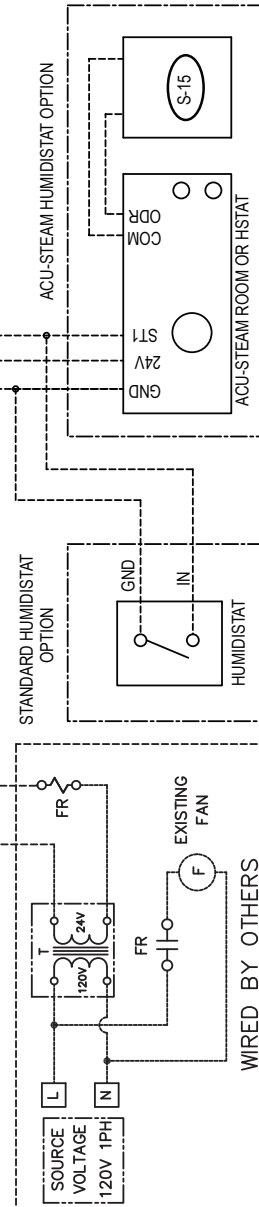

CONTRACTOR

INPUT / ENTRÉE
120 VAC

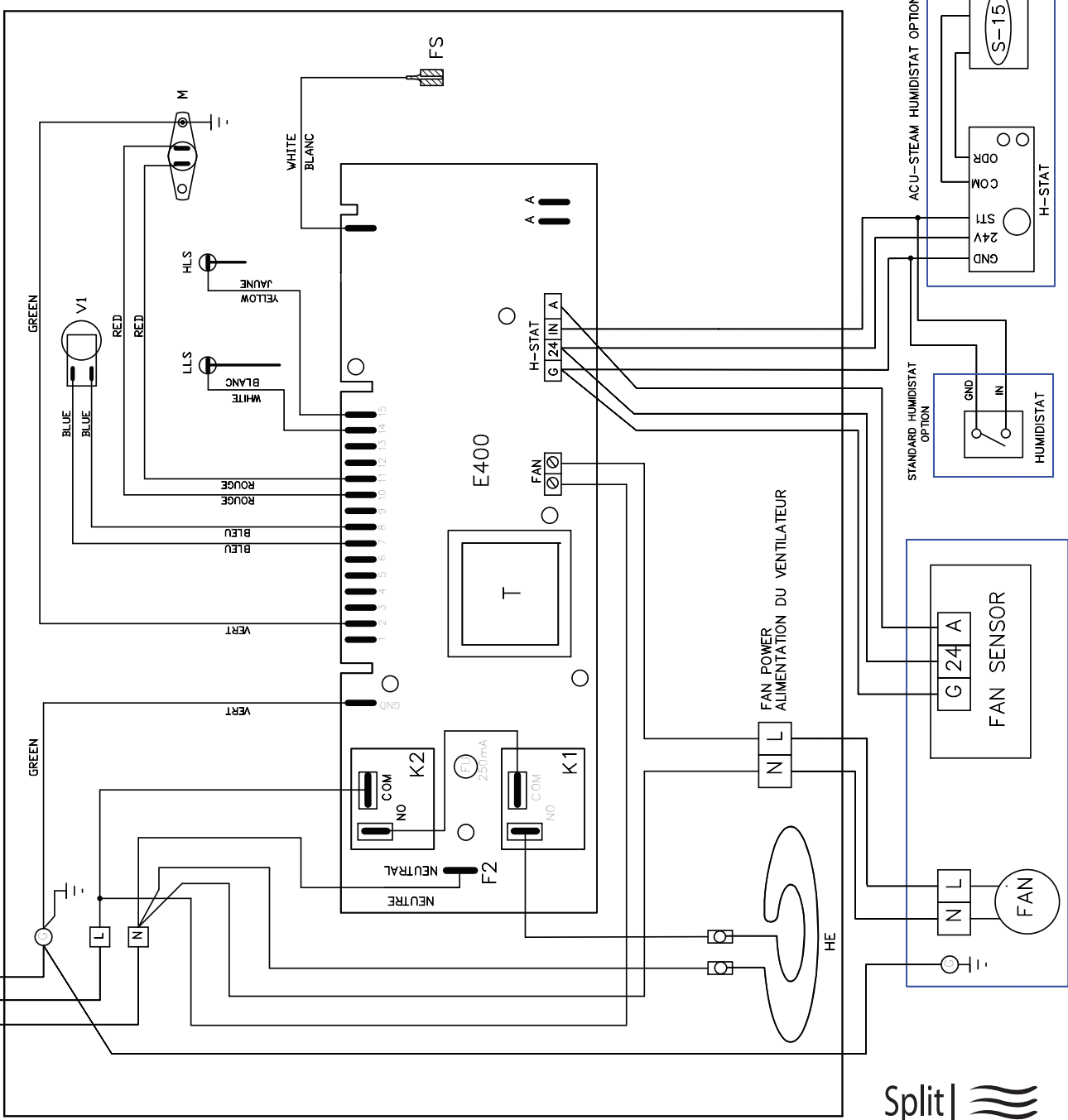

IMPORTANT:
WIRE IN ACCORDANCE TO LOCAL & NATIONAL ELECTRIC CODES. READ CAREFULLY INSTALLATION INSTRUCTIONS BEFORE WIRING AND OPERATING.

- LEGEND**
- E400 -- PRINTED CIRCUIT BOARD
 - M -- MANUAL RESET CUT-OUT 225°F
 - K1 -- OPERATING RELAY
 - K2 -- BACK-UP RELAY
 - LLS -- LOW LEVEL SENSOR
 - HLS -- HIGH LEVEL SENSOR
 - V1 -- ELECTRIC VALVE 24 VDC
 - T -- TRANSFORMER
 - FS -- FLOOD SENSOR
 - HE -- HEATING ELEMENT
 - H-STAT -- ROOM OR DUCT HUMIDISTAT
 - R -- FAN RELAY
 - GND -- GROUND CONNECTION
 - S-15 -- OUTDOOR SENSOR
 - FU -- CONTROL FUSE
 - FAN -- VENTILATEUR

IMPORTANT:
SUIVRE LES CODES ELECTRIQUES NATIONAUX ET LOCAUX AINSI QUE LES INSTRUCTIONS CONTENUES DANS L'APPAREIL.

- LEGENDE**
- E400 -- CIRCUIT IMPRIME
 - M -- SONDE THERMIQUE 225°F
 - K1 -- A REENCLENCHEMENT MANUEL
 - K2 -- RELAIS DE FONCTIONNEMENT
 - LLS -- RELAIS DE SÉCURITÉ
 - HLS -- CAPTEUR DE BAS NIVEAU
 - V1 -- CAPTEUR DE HAUT NIVEAU
 - T -- VALVE ÉLECTRIQUE 24VDC
 - FS -- TRANSFORMATEUR
 - HE -- CAPTEUR DE DEBOREMMENT
 - HE -- ÉLÉMENT CHAUFFANT
 - H-STAT -- HYGROSTAT DE PIÈCE
 - R -- RELAIS DE VENTILATEUR
 - GND -- PRISE DE TERRE
 - S-15 -- CAPTEUR EXTÉRIEUR
 - FU -- FUSIBLE DE CONTRÔLE
 - FAN -- FAN MODULE

ACU-5-SP 120V MODEL



IMPORTANT:

SUIVRE LES CODES ELECTRIQUES NATIONAUX ET LOCAUX AINSI QUE LES INSTRUCTIONS CONTENUES DANS L'APPAREIL.

LEGENDE

- E400 - CIRCUIT IMPRIME
- M - SONDE THERMIQUE 225°F A REGENLENCHEMENT MANUEL
- PDS - INTERRUPTEUR A DIFFERENTIEL DE PRESSION
- K1 - RELAIS DE FONCTIONNEMENT
- K2 - RELAIS DE SECURITE
- LLS - CAPTEUR DE BAS NIVEAU
- HLS - CAPTEUR DE HAUT NIVEAU
- V1 - VALVE ELECTRIQUE 24VDC
- T - TRANSFORMATEUR
- FS - CAPTEUR DE DEBOREDEMENT
- HE - ELEMENT CHAUFFANT
- H-STAT - HYGROSTAT DE PIECE
- R - RELAIS DE VENTILATEUR
- GND - PRISE DE TERRE
- S-15 - CAPTEUR EXTERIEUR
- FU - FUSIBLE DE CONTROLE

IMPORTANT:
WIRE IN ACCORDANCE TO LOCAL & NATIONAL ELECTRIC CODES. READ CAREFULLY INSTALLATION INSTRUCTIONS BEFORE WIRING AND OPERATING.

LEGENDE

- E400 - PRINTED CIRCUIT BOARD
- M - MANUAL RESET CUT-OUT 225°F
- PDS - PRESSURE DIFFERENTIAL SWITCH
- K1 - OPERATING RELAY
- K2 - BACK-UP RELAY
- LLS - LOW LEVEL SENSOR
- HLS - HIGH LEVEL SENSOR
- V1 - ELECTRIC VALVE 24 VDC
- T - TRANSFORMER
- FS - FLOOD SENSOR
- HE - HEATING ELEMENT
- H-STAT - ROOM OR DUCT HUMIDISTAT
- R - FAN RELAY
- GND - GROUND CONNECTION
- S-15 - OUTDOOR SENSOR
- FU - CONTROL FUSE

Acu-8-SP 240V

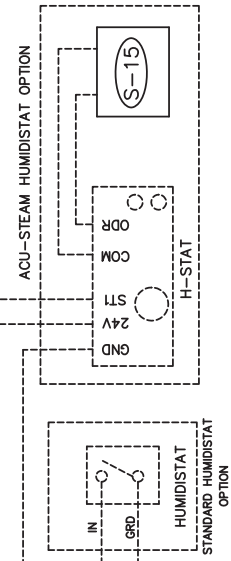
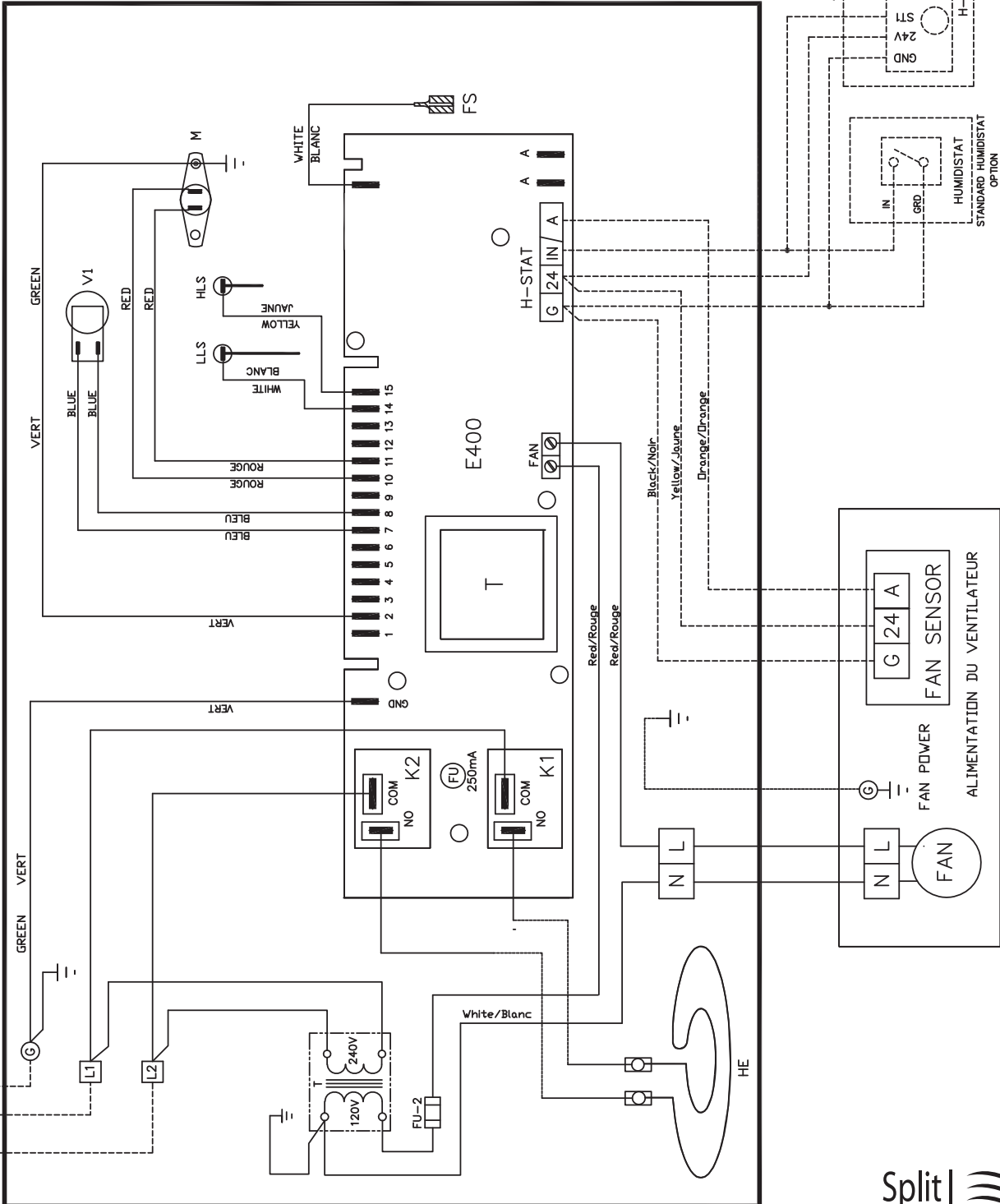

CONTRACTOR



22. Detailed Error Codes

Number of flashes of the red light	Error Description	Humidifier Status	Actions to be Taken by the Technician	Reset
OFF	No error	The humidifier is working fine	None	
Continuous ON	The flood sensor under the tank senses water in the pan.	Humidifier immediately suspends the ongoing operation. Heating elements and supply valve are switched off. The power green light is OFF.	Turn power off. Check for leaks around the tank clamp, SW valve and drain tube. Make sure tank arrows align and gasket is sealing properly.	Automatic Reset when Overflow pan dries up.
1	The two water level sensors are miswired or do not read the water level properly.	Humidifier attempts to operate, then stops because of wrong information from water level sensors. The power green light is blinking.	Turn power off. Clean or replace HLS or LLS water sensors. Check for proper wiring of HLS and LLS sensors.	Automatic Reset when switching main power ON
3	Inadequate water supply and/or marginal drainage. The supply valve was open for more than 6 minutes.	Humidifier immediately suspends the ongoing operation. Heating elements and supply valve are switched off. The power green light is ON.	Turn power off. Check SW valve circuit for 24V DC at the valve. Refer to manual (p. 20) and check for proper drain installation. Make sure SW shut-off valve is open, SW valve is responding and SW tube is clear of debris or else replace drain hose.	Automatic Reset after 5 min. of after switching main power on and off.
4	Inadequate drainage. The tank did not drain or the draining cycle is too long.	Humidifier immediately suspends the ongoing operation. Heating elements and supply valve are switched off. The power green light is blinking.	Turn power off. Check for proper drain setup by referring to manual (p. 20). Check and clean tank, SS siphon tube and silicon drain tube if necessary.	Automatic Reset when switching main power ON
 5	Fan not running	Humidifier immediately suspends the ongoing operation. The unit goes back to normal operation as soon as the error condition disappears. The power green light is blinking.	Check if the Fan motor is running. Call a service technician.	Automatic Reset when error conditions disappear
ACU=STEAM 5	The air pressure switch does not detect enough air pressure.	Humidifier immediately suspends the ongoing operation. The unit goes back to normal operation as soon as the error condition disappears. The power green light is ON.	Check if the FF motor is running. If not, turn FF to continuous operation. Check flow sensor (pitot tube) in duct for blockage, then make sure plastic tube is connected properly from flow sensor to PD switch under PC board in unit (see manual). Change furnace filter if needed.	Automatic Reset when error conditions disappear
6	Temperature inside the tank exceeded the high temperature cut-out setting.	The high temperature cut-out has tripped. The humidifier immediately suspends the ongoing operation. Heating elements and supply valve are switched off. The power green light is blinking.	Turn power off. This is a serious condition and will likely require assistance from a service technician. Call 1-800-336-9130.	After pushing on the thermal cut-out button, automatic reset when switching main power ON

Legend: SS = stainless steel, FF = furnace fan, SW = supply water, HLS = high level sensor, LLS = low level sensor

CONTRACTOR

ACU \approx STEAM[®]

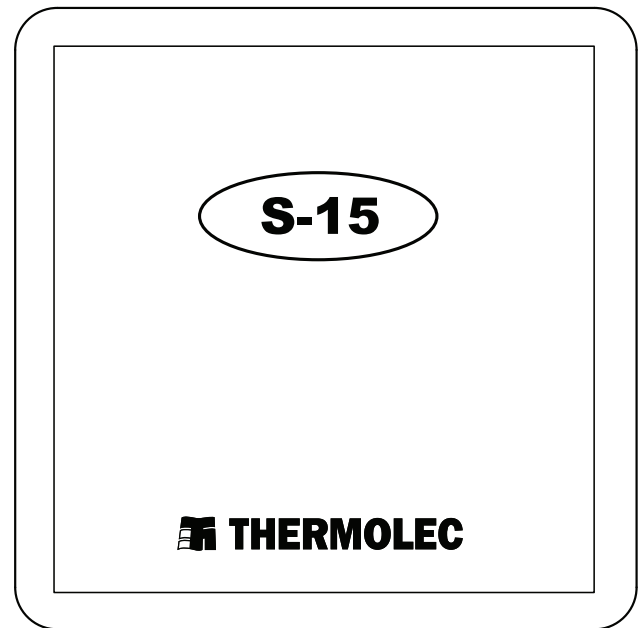
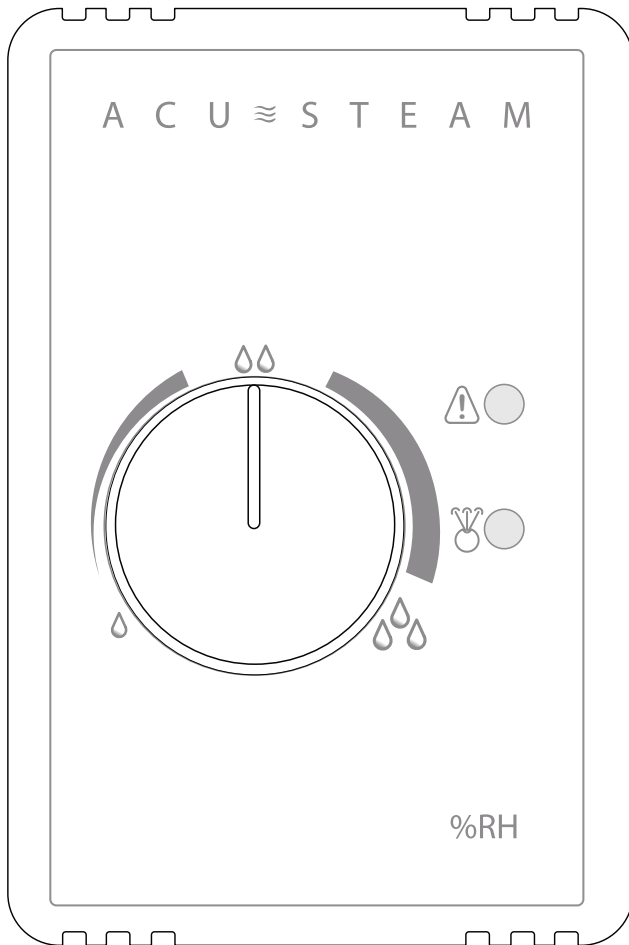

ELECTRONIC HUMIDISTAT AND OUTDOOR SENSOR INSTALLATION INSTRUCTIONS

ACU-STEAM HUMIDISTAT, version A

Features

- State of Art digital RH sensor
- ROOM or DUCT mounting
- Reprogrammable Microcontroller
- Potentiometer Set-point setting
- Out-door temperature sensor for Set-point Reset
- Green (ON/OFF) and Red (warning) status LEDs

Specifications

Set-point range. 20% to 50% Relative Humidity
Accuracy. $\pm 4.5\%$, without calibration
Linearity $\pm 1\%$ in the Set-point range
Differential % RH. $\pm 2\%$
Outdoor Temp. Reset Range between $-9\text{ }^{\circ}\text{F}$ ($-23\text{ }^{\circ}\text{C}$) to $27\text{ }^{\circ}\text{F}$ ($-3\text{ }^{\circ}\text{C}$)

Outdoor reset Temperature vs.	Set point change
32 °F (0 °C) and warmer	50% max,
32 °F (0 °C) to 25 °F (-4 °C)	42% max,
23 °F (-5 °C) to 19 °F (-7 °C)	38% max,
18 °F (-8 °C) to 14 °F (-10 °C)	34% max,
12 °F (-11 °C) to 7 °F (-14 °C)	30% max,
5 °F (-15 °C) to 0 °F (-18 °C)	26% max,
-2 °F (-19 °C) to -6 °F (-21 °C)	22% max,
-8 °F (-22 °C) and colder	20% max.

NOTE: these ranges can vary by $\pm 5\%$.

The Outdoor Temperature sets the maximum set point of RH internally.
If the Dial position is higher, the actual set point will be limited as above.

Installing and Connecting the ACU-STEAM Humidistat and the Outdoor Sensor

1.1 The humidity sensor is not located at the same place in a wall mount or in a duct mount humidistat and therefore the two models of humidistats are not interchangeable. Please see [Fig.1a](#) and [Fig.1b](#).

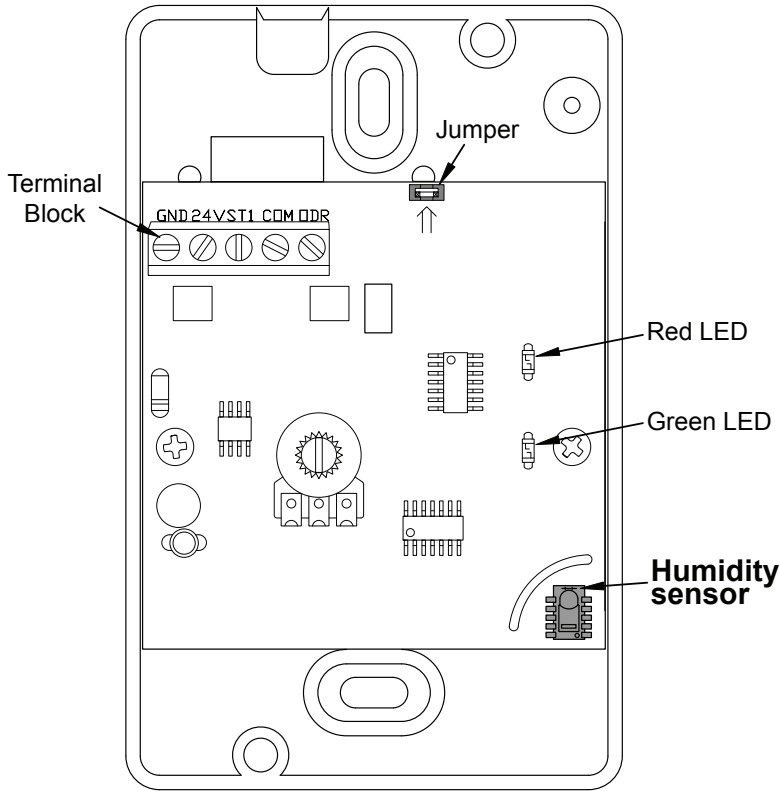

Fig. 1a Wall Mount Humidistat

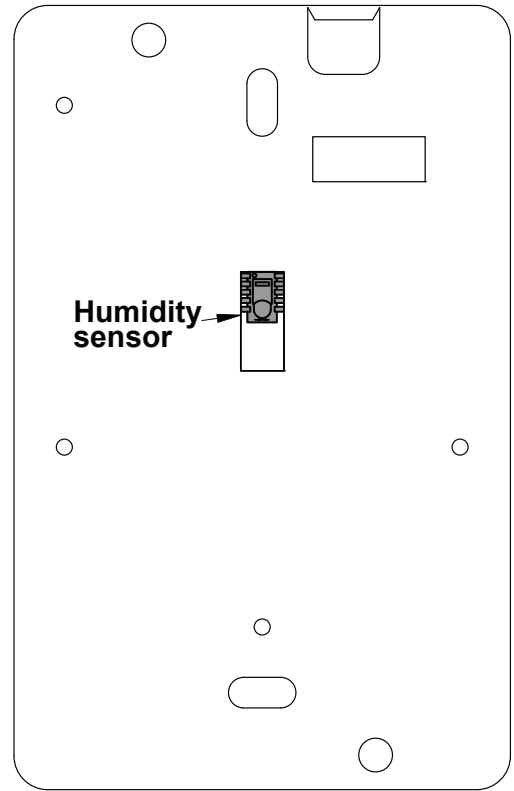

Fig. 1b Back View of a Duct Mount Humidistat

1.2 A three wire control cable (not supplied) has to be connected between the wall (or duct) electronic humidistat and the humidifier electronic board at the three terminals marked "H-STAT".

Please respect the sequence and connect

GND to GND 24V to 24V ST1 to IN

1.3 The outdoor sensor **S-15** (please see [Fig.1c](#)) is supplied with the humidistat (wall or duct mount). It ideally should be installed on an outside wall facing North. This outdoor sensor automatically reduces the setting of the humidistat according to the outdoor temperature in order to avoid condensation on windows during extremely cold days. It does the opposite during the mild days without your having to manually adjust the humidistat. The outdoor sensor is a 10 kilo-ohms NTC thermistor (negative temperature coefficient).

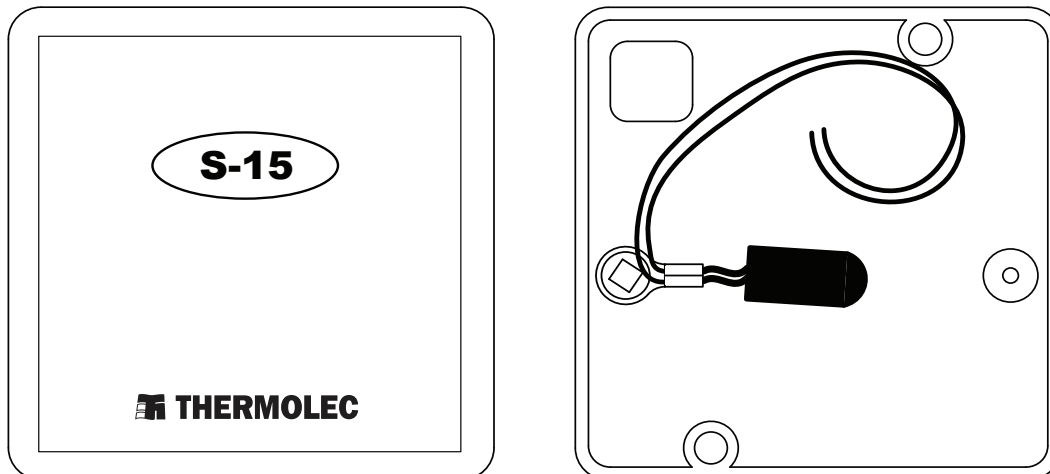
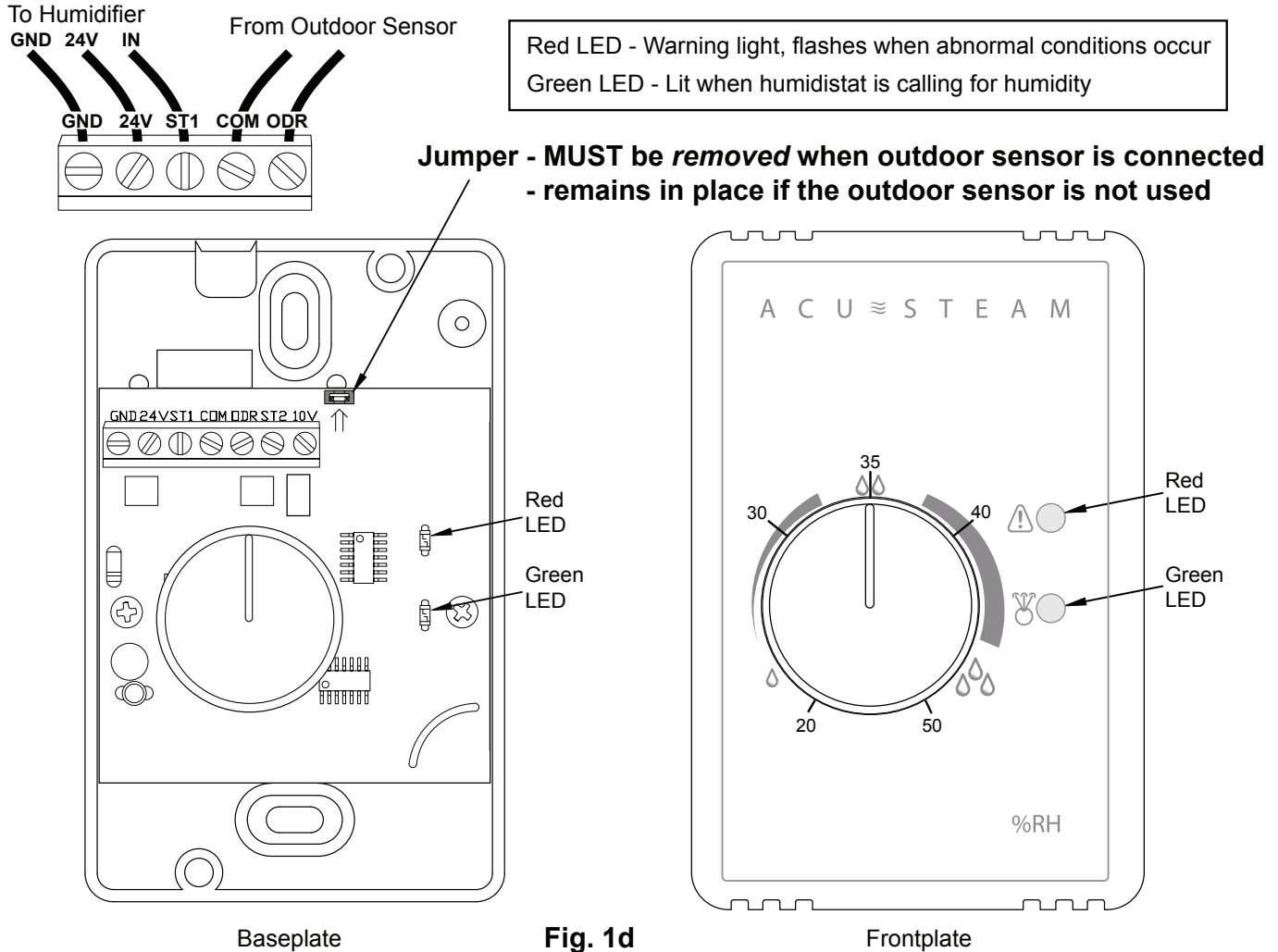

Fig. 1c

1.4 A two wire control cable is required to connect the outdoor sensor to the terminals marked **COM** & **ODR** on the electronic humidistat. Please see Fig. 1d. The outdoor sensor is not polarized so there is no wiring polarity to follow.



IMPORTANT : Whenever an outdoor sensor is connected to the electronic humidistat, **the jumper located at the top of the electronic board must be removed so that the outdoor sensor becomes operational** (i.e. the jumper short circuits the terminals dedicated to the outdoor sensor). If the outdoor sensor is not installed, **keep the jumper in place.**

1.5 To force a drain cycle when the humidifier is running and producing steam, simply turn down the humidistat. Please note that when using an ACU-STEAM electronic humidistat, if the relative humidity is extremely low the humidifier may still run with the knob at the minimum setting because of a range limiter inside the cover. If this occurs you will need to remove the humidistat cover by pulling it off and turn the knob counter-clockwise to the minimum setting. The humidifier should now stop and drain.

Drilling Template for Duct Mount Humidistat

