

# PRO 600 Humidifier

Electronically controlled FLOW-THRU model

REVISED VERSION

JULY 2005

This humidifier is a flow through model and **MUST** be connected to a drain.

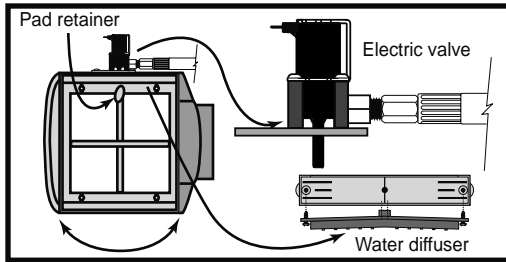

## 1 Preparing the unit.

This unit is reversible. Although not mandatory, use on the hot air duct will improve performance. Find the best location and determine how the humidifier will be installed. Select the top. Install and fasten the water diffuser, the long black plastic piece, with two screws #6 x 1/2" inside of the top part of the humidifier. Install the solenoid valve (mounted on a plastic bracket) outside of the top of the humidifier. While supporting the water diffuser with one hand, insert the plastic tube protruding from the valve into the hole in the middle of the top part of the humidifier making sure that the plastic tubing is firmly seated in the hole of the water diffuser. Fasten the valve assembly to the unit with screws # 6 x 1/2". Finally, install the plastic pad retainer by snapping it in the hole located in the middle of the humidifier frame.

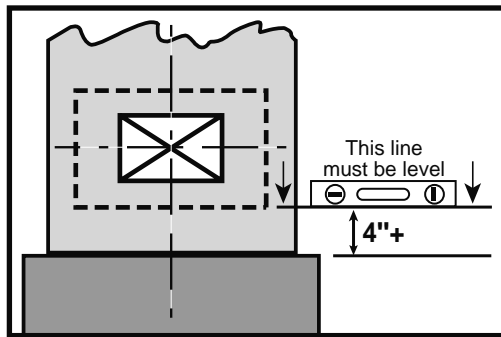

## 2 Cutting the opening.

Draw a level line at 4 inches minimum above the furnace housing for clearance of the drain tube. Attach the template to the duct. Punch and drill the four corners for the opening and the four fastening holes with a 3/32" drill. Remove the template and complete the opening outline. Cut the opening in the plenum.

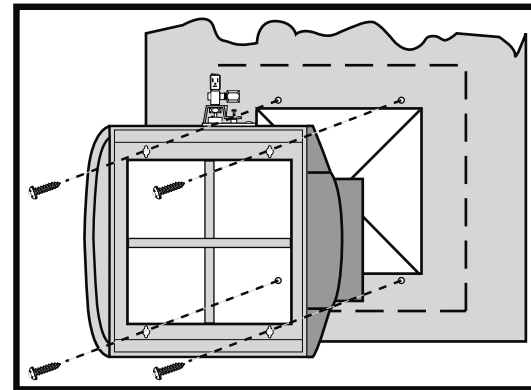

## 3 Installing the unit.

Install the unit in the opening. Use the four screws (#8 x 3/4") to attach the humidifier body to the duct. The ribs around the humidifier back opening must fit into the rectangular opening in the duct. Check that the humidifier body is level from side to side. Then fasten the unit completely.

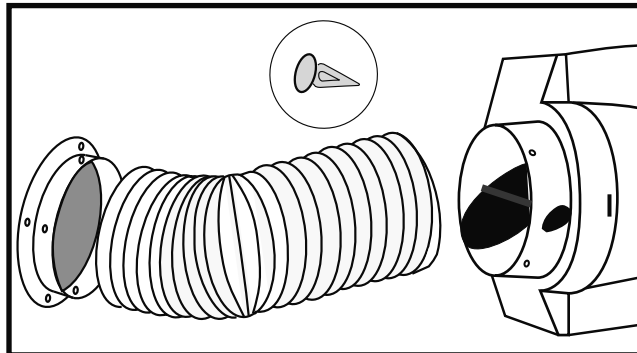

## 4 Installing the collar and the flex duct.

Install the 6" metal collar in a convenient location on the opposite duct with four screws (#8 x 3/8"). The flex duct is preinstalled on the humidifier damper. Slide the damper assembly into the side opening of the humidifier until it snaps. Make sure to position the damper knob in front of the unit. Measure the required flex duct length to the metal collar so it does not sag. Cut the excess portion. Slide the flexible duct on the air take-off collar and secure it by inserting the plastic pins through the vinyl in between two reinforcement wires.

## 5 Installing the drain tube.

Select a convenient drain location for running the drain tube. Before you connect the tube to the drain fitting, slip the hose clamp over the tube. Push the drain tube (1/2" I.D.) over the drain fitting located at the bottom of the unit and secure it in place with the hose clamp. Make sure the tube has no bends and the water can flow easily in a straight manner to the drain without accumulating in the tube.

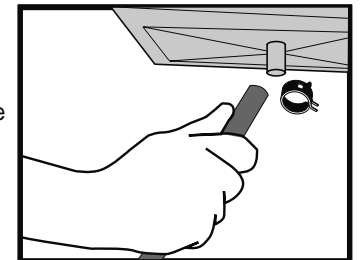

## 6 Installing the evaporator pad.

The pad is enclosed in a plastic frame having molded markings that clearly indicates the bottom. Slide the pad into the bottom part of the humidifier, the little bump at the top facing to you, then push the pad against the back opening of the humidifier. Lock the pad in place with the pad retainer.

### 7. Connecting the water supply tubing to the water hammer absorber and the valve

- This water hammer absorber is connected to the electric valve in factory.
- Install the water supply tubing on the other side of the rubber hose. That side has a compression fitting to receive the supply tubing.
- Slip the brass compression nut onto the plastic supply tube, then the nylon sleeve with its most tapered end towards the end of the tube. Finally, install a brass insert into the end of the plastic tubing.
- Push the supply tube fully into the brass compression fitting. Tighten the brass compression nut with small wrenches, without stripping, using the double wrench method in order to apply the torque on the fitting only.

- Then do the same operation at the other end of the supply tube and make the connection to the saddle valve previously installed on the copper supply pipe.
- Turn the valve handle completely clockwise until it stops. This will pierce the copper pipe and close the valve.
- This saddle valve is designed to be fully open or closed. Do not use it to adjust the water flow.

**NOTE :** The brass sleeve supplied with the brass valve Kit #10 is to be used only if the plastic tubing is replaced by copper tubing (not recommended).

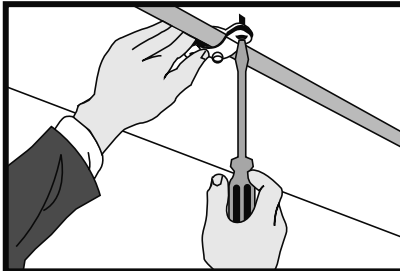
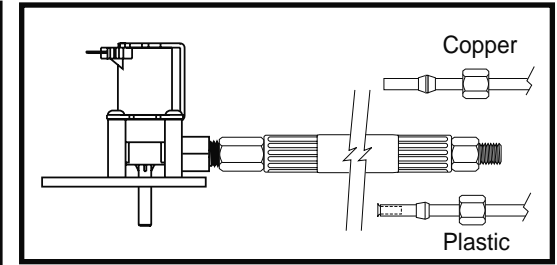
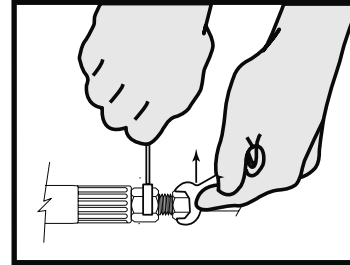

### 8 Installing the water supply valve.

The water supply is taken from the nearest suitable cold, hot, softened or unsoftened water line.

The use of service hot water (140°F / 60°C Max) improves the evaporative capacity (this model **reduces drained water by 80 %**).

Note: Do not use the saddle valve to regulate water flow. It is designed to be fully opened or closed.

### 9 Installing the electronic controller.

The HSA 038 electronic controller can be installed anywhere. When switched ON by the humidistat, it opens the electric valve for approximately 2 seconds and then closes the valve for another 30 seconds, and so on.

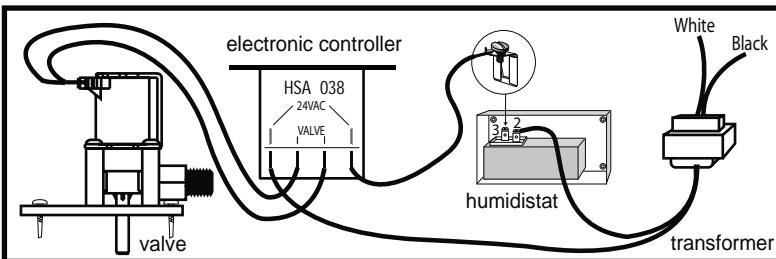
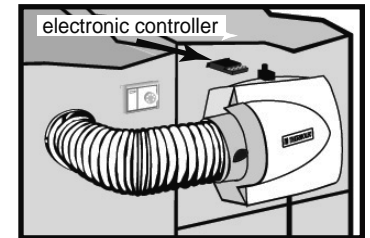

### 10 Installing the transformer.

The transformer supplied is for 120 volts operation only. Do not install it on a furnace supplied with another voltage. Connect the transformer primary to the relay activated when the furnace is in a heating cycle. Some furnaces have power terminals that can be used for accessories. Please refer to the furnace installation manual.

### 11 Installing the humidistat and final wiring.

Kit No. 4B contains all the material you need to install the humidistat. The humidistat should be installed on a flat and vertical surface of the RETURN duct. Attach the humidistat template on the return duct at 6 inches minimum from the humidifier top. Mark and drill the mounting holes and cut an opening for the humidistat. Push the two quick connectors on the humidistat terminals. Run the two humidistat wires through a little opening located at the bottom of the front panel. Install the humidistat in the opening and fasten it to the duct.

The mechanism is exposed in the duct. Check that the metal of the duct neither touches the connections nor cuts the wire insulation.

Complete the wiring of the humidistat according to the above diagram.

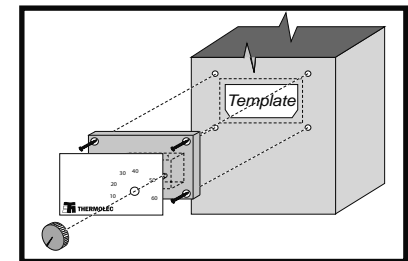

### 12 Humidifier Start-up.

Open the saddle valve, put the furnace power back on and start the furnace in a heating cycle. Set the humidistat at the maximum setting.

After a few ON/OFF cycles of the electric valve, you should see water flowing through the drain tube. Check that the water is evenly distributed by the water diffuser across the pad. Carefully check that both ends of the water supply tube are firmly held in place by their respective compression fitting. After peeling off the backing, affix the faceplate to the cover of the humidistat and re-install the control knob. Set the humidistat according to the recommended setting on the label. Check the system several times to make sure there is a free flow in the drain tube and there is no leak before leaving the installation unattended. When everything is working fine, affix the adhesive nameplate on the humidifier cover.

Note for the contractor:  
**Please ensure that customer receives the owner's manual.**

**Note: This template is only a reference and not drawn to scale.**

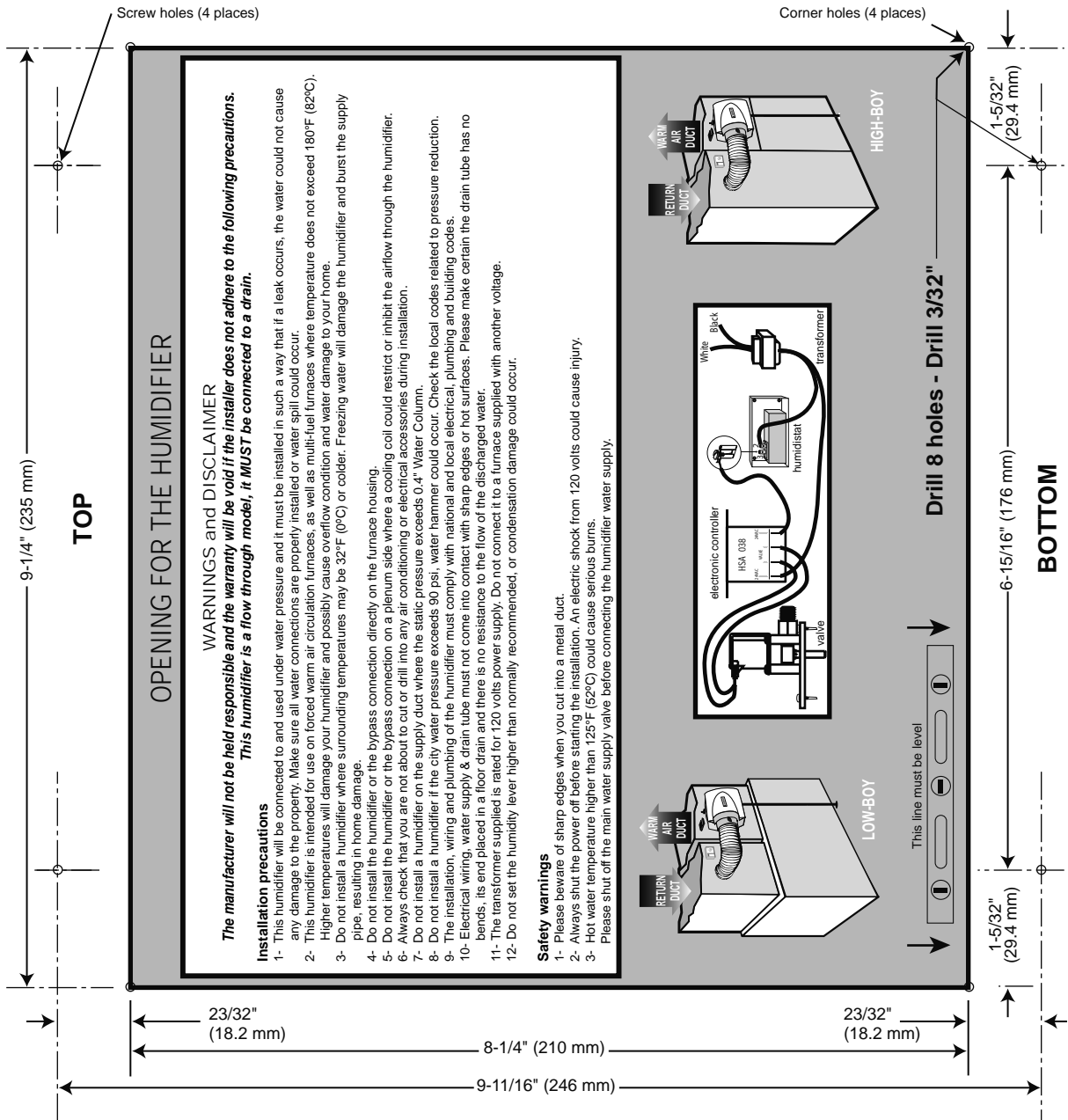

## Model PRO 600

### Electronically Controlled Pulsed Flow Humidifier

Please read the instructions carefully before starting the installation.

This humidifier must be installed by a qualified heating and air conditioning contractor.

The Pro 600 model can be installed on either the supply or return plenum of a forced air heating system. It is easily reversible for right or left hand.

The total dimensions are: 15" x 15" x 9".

The opening in the duct is 9-1/4" x 8-1/4".

In selecting the best location for the unit, please take both dimensions and serviceability in consideration.

If the furnace is equipped with a central cooling system, the damper of the unit should be closed during the cooling season.

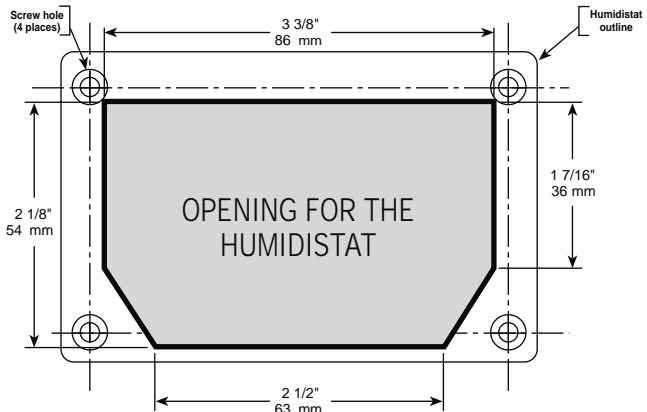

**Note: This template is only a reference and not drawn to scale.**