

The P37 is a Pneumatic-electronic transducer that converts a 2-13 psi input into a proportional Pulse or 0-10VDC output and therefore replaces both the P35 and P36. For ease of use the board is programmed for 3-8 psi Pulse output selectable from the MODE DIP SWITCHES in Direct or Reverse Acting mode. If a custom range is required in either a Pulse or 0-10 VDC output, please follow the calibration instructions below. **Turn the power off before changing the DIP SWITCH settings.**

MODE DIP SWITCH SETTINGS:

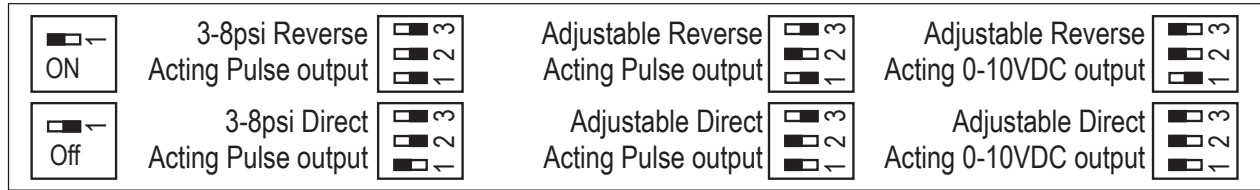

SAMPLE WIRING FOR D21-P, D22-P OR D21-PS CONTROLLERS:

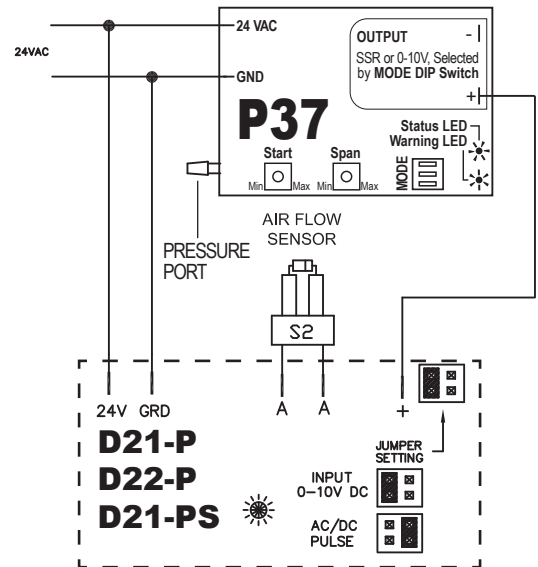
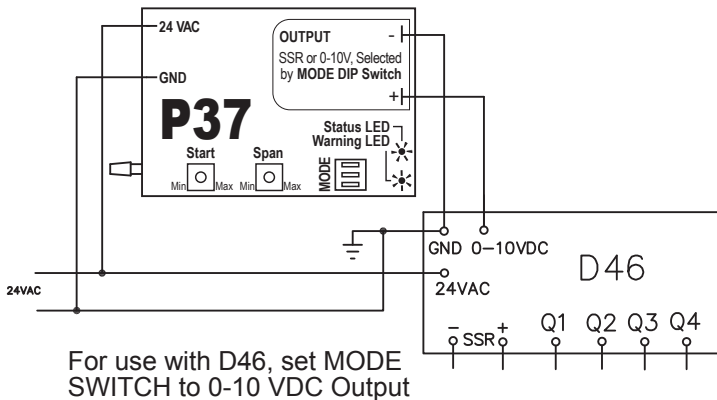
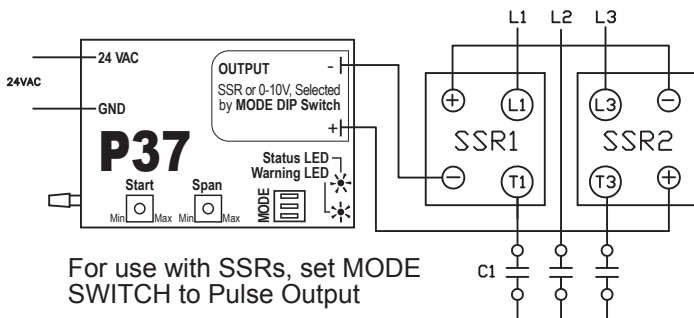

For use with D21-P, D22-P or D21-PS board set MODE SWITCH to 0-10 VDC and connect the positive output to the positive input on the D2x-P series board and place the jumper on the 0-10VDC position.

Never short the positive and negative outputs on the P37 when wiring. This will cause permanent damage to the board. The negative output is only used when connecting the P37 directly to Solid State Relays (maximum 4).

CALIBRATION INSTRUCTIONS:

Note: The START Pot range is from 2 to 9 psi. and the SPAN Pot range is from 6 to 13 psi. The SPAN minus START value should be at least 4 psi. The Warning (yellow) LED will light if the range is not valid and the Status (red) LED only lights in Pulse output mode.

To adjust the P37 for a custom range other than the fixed modes available with DIP switch settings: (example 4 - 9 psi)

Set the DIP switches to the appropriate adjustable setting of Direct or Reverse acting and *Pulse* output. If you require a 0-10VDC output select this setting after the calibration is complete. Disconnect any output wiring from the board leaving only the 24V power. Adjust the START Pot to the minimum (counterclockwise) setting and the SPAN Pot to the maximum (clockwise).

Using a calibrated pressure source connect the hose to the Pressure Port and apply the required Start pressure (e.g. 4 psi). The red LED may be blinking at this point and there will be a slight delay in the response of the controller. Slowly turn the START pot clockwise until the LED is ON for Reverse Acting or OFF for Direct Acting. Now apply the required Span pressure (e.g. 9 psi). Slowly turn the SPAN pot counterclockwise until the red LED is OFF for Reverse Acting or ON for Direct Acting. Apply the start pressure again and fine tune the START pot if required.

Turn off the power and reconnect the output wiring to the board. If a 0-10VDC output is required adjust the DIP switches now. Calibration is now complete.